

SUZUKI

OWNER'S MANUAL

GSX1100S

THANK YOU for choosing Suzuki. We at Suzuki have designed, tested and produced this motorcycle using the most modern technology available to provide you with many happy, enjoyable, safe miles of riding. Motorcycling is one of man's most exhilarating sports and to insure your riding enjoyment, you should become thoroughly familiar with the information presented in this Owner's Manual before riding the motorcycle.

The proper care and maintenance that your motorcycle requires is outlined in this manual. By following these instructions explicitly you will insure a long trouble free operating life for your motorcycle. Your Suzuki dealer has experienced technicians that are trained to provide your machine with the best possible service with the right tools and equipment.

SUZUKI MOTOR CO.,LTD.

OWNERS CLUB
U.K.

Please read this manual and follow its instructions carefully.

*To emphasize special information the words **WARNING**, **CAUTION** and **NOTE** carry special meanings and should be carefully reviewed.*

WARNING The personal safety of the rider may be involved. Disregarding this information could result in injury to the rider.

CAUTION These instructions point out special service procedures or precautions that must be followed to avoid damaging the machine.

NOTE Special information to make maintenance easier or important instructions more clear.

Copying, quoting or reproducing any part of this manual is not permitted without explicit approval by SUZUKI MOTOR CO., LTD.

All information, illustrations and specifications contained in this manual are based on the latest product information available at the time of publication. Due to improvements or other changes, there may be some discrepancies in this manual. Suzuki reserves the right to make changes at any time.

Your motorcycle might differ in minor respects from the contents in this manual. This is because some minor modifications had to be made in the motorcycle to comply with statutory requirements of your country.

This motorcycle may not comply with the emission, noise and safety regulations of other countries. Before attempting to register this motorcycle in any other country, check all applicable regulations and make any necessary modifications.

CONSUMER INFORMATION	4
Accessory Installation and Precaution Safety Tips	4
Safe Riding Recommendation for Motorcycle Riders	6
Serial Number Location	7
LOCATION OF PARTS	8
CONTROLS	9
FUEL AND ENGINE OIL RECOMMENDATION	18
BREAK-IN	19
INSPECTION BEFORE RIDING	20
RIDING TIPS	21
PERIODIC MAINTENANCE SCHEDULE	31
INSPECTION AND MAINTENANCE	33
TROUBLESHOOTING	64
STORAGE PROCEDURES	65
SPECIFICATIONS	66
WIRING DIAGRAM	68

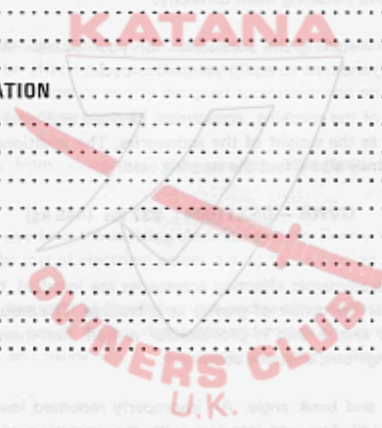

ACCESSORY INSTALLATION AND PRECAUTION SAFETY TIPS

There are a great variety of accessories available to Suzuki owners. Suzuki can not have direct control over the quality or suitability of accessories you may wish to purchase. The addition of unsuitable accessories can lead to unsafe operating conditions. It is not possible for Suzuki to test each accessory on the market or combinations of all the available accessories; however, your dealer can assist you in selecting quality accessories and installing them correctly.

Use extreme caution when selecting and installing the accessories for your Suzuki. We have developed some general guidelines which will aid you when deciding whether, and how to equip your motorcycle.

- (1) The GVWR is the combined weight of the machine, accessories, payload and rider. When selecting your accessories, keep in mind the weight of the rider as well as the weight of the accessories. The additional weight of the accessories may not only create an unsafe riding condition but may also affect the steering ease.

GVWR – GSX1100S : 937 lbs (445 kg)

- (2) Anytime that additional weight or aerodynamic affecting accessories are installed, they should be mounted as low as possible, as close to the motorcycle and as near the center of gravity as is feasible. The mounting brackets and other attachment hardware should be carefully checked to ensure that it provides for a rigid, non-moveable mount. Weak mounts can allow the shifting of the weight and create a dangerous, unstable condition.
- (3) Inspect for proper ground clearance and bank angle. An improperly mounted load could critically reduce these two safety factors. Also determine that the "load" does not interfere with the operation of the suspension, steering or other control operations.

- (4) Accessories fitted to the handlebars or the front fork area can create serious stability problems. This extra weight will cause the motorcycle to be less responsive to your steering control. The weight may also cause oscillations in the front end and lead to instability problems. Accessories added to the handlebar or front fork of the machine should be as light as possible and kept to a minimum.
- (5) Windshields, fairings, backrests, saddlebags, travel trunks, etc., may affect the stability of the motorcycle due to their aerodynamic effects. The motorcycle may be affected by a lifting condition or by an instability in cross winds or when being passed or passing large vehicles. Improperly mounted or poorly designed accessories can result in an unsafe riding condition, therefore, caution should be used when selecting and installing all accessories.
- (6) Certain accessories displace the rider from his normal riding position. This limits the freedom of movement of the rider and may limit his control ability.
- (7) Additional electrical accessories may overload the existing electrical system. Severe overloads may damage the wiring harness or create a dangerous situation due to the loss of electrical power during the operation of the motorcycle.

When carrying a load on the motorcycle, mount it as low as possible and as close as possible to the machine. An improperly mounted load can create a high center of gravity which is very dangerous and makes the motorcycle difficult to handle. The size of the "load" can also affect the aerodynamics and handling of the motorcycle. Balance the load between the left and right side of the motorcycle and fasten it securely.

SAFE-RIDING RECOMMENDATION FOR MOTORCYCLE RIDERS

Motorcycle riding is great fun and an exciting sport. Motorcycle riding also requires that some extra precautions be taken to ensure the safety of the rider and passenger. These precautions are:

WEAR A HELMET

Motorcycle safety equipment starts with a quality safety helmet.

One of the most serious injuries that can happen is a head injury. **ALWAYS** wear a properly approved helmet. You should also wear suitable eye protection.

RIDING APPAREL

Loose fancy clothing can be uncomfortable and unsafe when riding your motorcycle. Choose good quality motorcycle riding apparel when riding your motorcycle.

INSPECTION BEFORE RIDING

Review thoroughly the instructions in the "INSPECTION BEFORE RIDING" section of this manual. Do not forget to perform an entire safety inspection to ensure the safety of the rider and its passenger.

FAMILIARIZE YOURSELF WITH THE MOTORCYCLE

Your riding skill and your mechanical knowledge form the foundation for safe riding practices. We suggest that you practice riding your motorcycle in a non-traffic situation until you are thoroughly familiar with your machine and its controls. Remember practice makes perfect.

KNOW YOUR LIMITS

Ride within the boundaries of your own skill at all times. Knowing these limits and staying within them will help you to avoid accidents.

BE EXTRA SAFETY CONSCIOUS ON BAD WEATHER DAYS

Riding on bad weather days, especially wet ones, requires extra caution. Braking distances double on a rainy day. Stay off of the painted surface marks, manhole covers and greasy appearing areas as they can be especially slippery. Use extreme caution at railway crossings and on metal gratings and bridges. Whenever in doubt about road conditions, slow down!

SERIAL NUMBER LOCATION

The frame and/or engine serial numbers are used to register the motorcycle. They are also used to assist your dealer when ordering parts or referring to special service information:

The frame number is stamped on the steering head tube. The engine serial number is stamped on the right side of the crankcase assembly.

Please write down the numbers here for your reference.

Frame No.

Engine No.

IGNITION SWITCH



Frame number

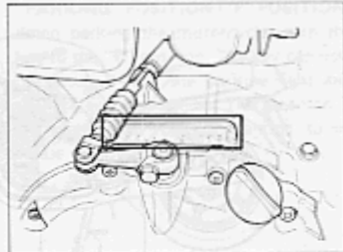

Engine number

OWNERS CLUB
U.K.

LOCATION OF PARTS

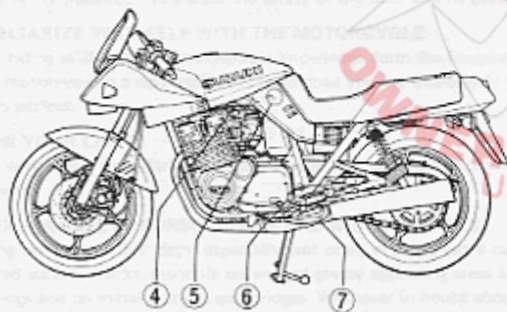
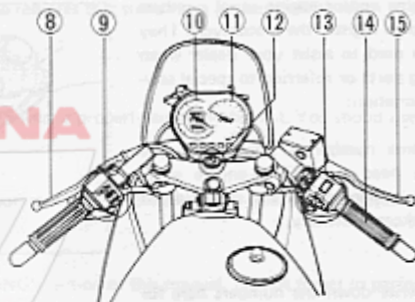
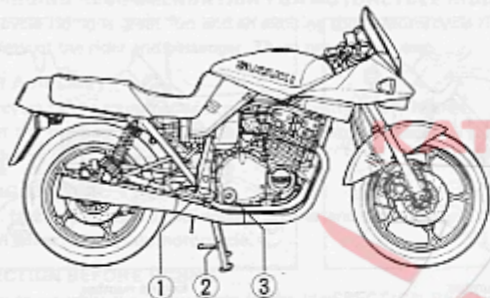

- | | |
|--------------------------------|--------------------------|
| ① Rear brake pedal | ⑨ Left handlebar switch |
| ② Center stand | ⑩ Speedometer |
| ③ Engine oil inspection window | ⑪ Tachometer |
| ④ Fuelcock | ⑫ Ignition switch |
| ⑤ Carburetor choke lever | ⑬ Right handlebar switch |
| ⑥ Gearshift lever | ⑭ Throttle grip |
| ⑦ Side stand | ⑮ Front brake lever |
| ⑧ Clutch lever | |

CONTROLS

KEY

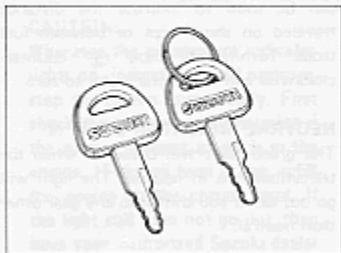

This motorcycle comes equipped with two (2) identical keys. Keep the spare key in a safe place.

Your motorcycle ignition keys are stamped with an identifying number. This number is used when making replacement keys.

Please write your key number in the box provided for your future reference.

IGNITION SWITCH

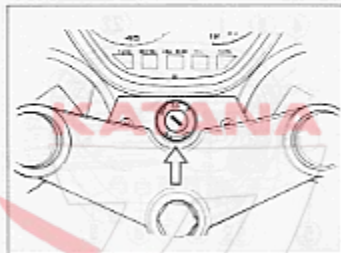

The ignition switch has three (3) positions:

"OFF" POSITION

All electrical circuits are out off.

"ON" POSITION

The ignition circuit is completed and the engine can now be started. The key cannot be removed from the ignition switch in this position.

"PARKING" POSITION ("P" POSITION)

When parking the motorcycle, turn the key to the "P" position. The key can now be removed and the parking light and taillight will remain lit. This position is for night time roadside parking to increase visibility.

TURN SIGNAL OPERATION

Pushing the signal operating switch to the right or left lights up the right-hand or left-hand turn signal respectively, in that order. Returning the switch to the "off" position will cancel the signal. The signal will not

STEERING LOCK

To lock the steering, turn the handlebar all the way to the right, insert the key in the steering lock, push down and turn the key clockwise. Do not forget to lock the steering when parking the motorcycle.

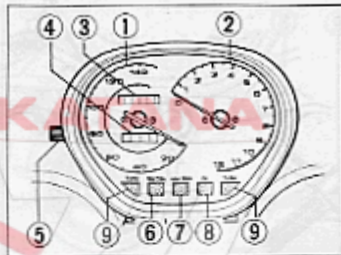
INSTRUMENT PANEL**SPEEDOMETER ①**

The speedometer indicates the road speed in miles per hour and kilometers per hour.

TACHOMETER ②

The tachometer indicates the engine speed in revolutions per minute (r/min).

ODOMETER ③

The odometer registers the total distance that the motorcycle has been ridden.

TRIP METER ④

The trip meter is a resetable odometer located in the speedometer assembly. It

can be used to indicate the distance traveled on short trips or between fuel stops. Turning the knob ⑤ counter-clockwise will return the meter to zero.

NEUTRAL INDICATOR LIGHT ⑥

The green light will come on when the transmission is in neutral. The light will go out when you shift into any gear other than neutral.

HIGH BEAM INDICATOR LIGHT ⑦

The blue indicator light will be lit when the headlight high beam is turned on.

OIL PRESSURE INDICATOR LIGHT ⑧

With the ignition switch in the "ON" position but the engine not started, the oil pressure indicator light should be lit. As soon as the engine is started, the light should go out.

CAUTION:

Whenever the oil pressure indicator lights up, indicating no oil pressure, stop the engine immediately. First check the oil level and determine if the proper amount of oil is in the engine. If the oil level is low, refill the engine to the correct level. If the light still does not go out, then have your authorized Suzuki dealer inspect your motorcycle to determine the difficulty. Do not operate the motorcycle when the light is lit as it may cause serious damage to the internal parts of the engine or transmission.

TURN SIGNAL INDICATOR LIGHT ①

When the turn signals are being operated either to the right or left side, the amber indicator light will flash.

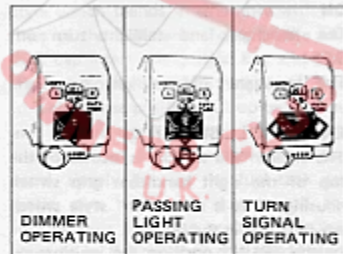
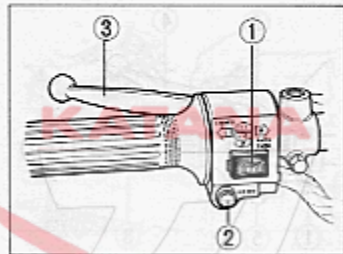
LEFT HANDLEBAR**LIGHTS OPERATING SWITCH ①
DIMMER OPERATING**

When the lights operating switch is pushed up to the "HIGH" position, the high beam will be lit and the switch return to the center position. At the same time that the high beam is lit, the high beam indicator will also light in the center instrument panel. When the switch is pushed down to the "LO" position, the low beam will be lit and the switch return to the center position.

PASSING LIGHT OPERATING

The headlight can be operated by pushing down under "LO" position the lights operating switch regardless of the lighting switch position. When passing a vehicle, push the passing light button repeatedly to call attention of driver ahead.

TURN SIGNAL OPERATING

Pushing the lights operating switch to the right or left lights up the right-hand or left-hand turn signal respectively, in that order. Returning the switch to center position puts out the signal, but you need not

do so if a self-cancelling device is provided on the machine. After running for approx. 10 seconds total with a speed of 15 km/h (9.3 mph) or higher after switching on a turn signal, the cancelling device automatically turns off the light switch. The cancelling device works like a timer, counting time only when the machine is running with the above-indicated speed. "10 seconds total" thus excludes any low-speed running duration.

WARNING:

Always use the turn signal when you intend to change lanes or make a turn.

HORN BUTTON ②

Press the button to operate the horn.

CLUTCH LEVER ③

The clutch lever is used to disengage the drive to the rear wheel when starting the engine or shifting the transmission gear. Squeezing the lever disengages the clutch.

RIGHT HANDLEBAR

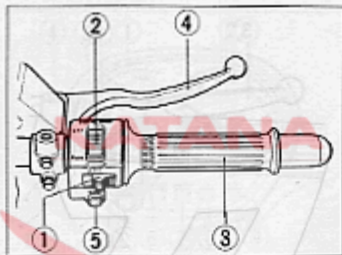

LIGHTING SWITCH ①

ON

The headlight and taillight turn on.

OFF

The headlight and taillight turn off.

ENGINE KILL SWITCH ②

The engine "kill switch" is located on the top of the right handlebar grip switch housing. This is a "rocker" style switch which pivots in the center.

In the "RUN" position the ignition circuit is on and the engine will operate. The switch is intended primarily as a safety or

emergency switch. When the switch is in the "OFF" position neither the starter motor nor the ignition circuit will be energized.

THROTTLE GRIP ③

Engine speed is controlled by the position of the throttle grip. Twist it toward you to increase engine speed. Turn it away from you to decrease the engine speed.

FRONT BRAKE LEVER ④

The front brake is applied by squeezing the brake lever gently towards the throttle grip. This motorcycle is equipped with a disc brake and excessive pressure is not required to slow the machine down properly. The brake light will be lit when the lever is squeezed inward.

ELECTRIC STARTER BUTTON ⑤

Push the electric starter button in to engage the starter motor.

The transmission should be in neutral for safety and the clutch disengaged during starting.

CAUTION:

Do not engage the starter motor for more than five seconds at a time as it may overheat the wiring harness and starter motor. If the engine does not start after several attempts, check the fuel supply and ignition systems. (Refer to the troubleshooting section.)

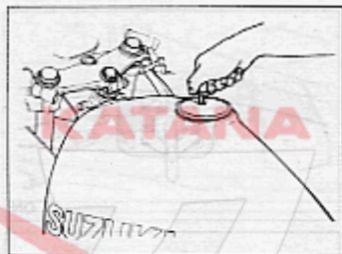
FUEL TANK CAP

The fuel tank cap is a new low profile style which blends in smoothly with the lines of the fuel tank. To open the fuel tank cap insert the ignition key and turn the key clockwise. With the key still held in a clockwise position, lift up on the key and remove the filler cap. To install the fuel tank cap, face the arrow mark forward, simply line up the fuel tank cap guide pins and push down until the locking pins click into position. The key must be in the cap lock or turned before installing cap. Turn the key counter-clockwise and remove it.

WARNING:

When re-fueling, always shut the engine off and turn the ignition key to the "OFF" position. Never re-fuel near an open flame.

CARBURETOR CHOKE LEVER

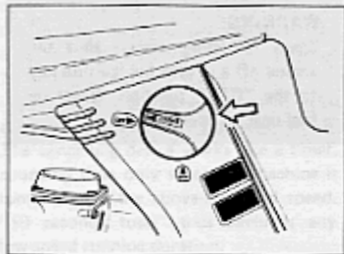

The carburetors of this motorcycle is equipped with a "choke" system to provide easy starting. When starting the cold engine, pivot the choke lever all the way to the "ON" position and engage the electric starter. After the engine starts, try to limit the engine RPM to approximately 2,000 RPM by varying the choke lever position. The choke system will operate only when the throttle is in the closed position as operating the throttle will bypass the choke system. Always be certain to pivot the choke lever to the "OFF" position after the engine reaches normal operating temperatures.

FUELCOCK

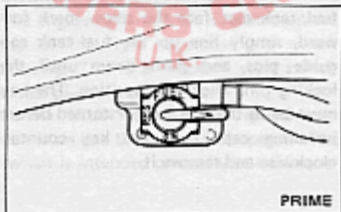
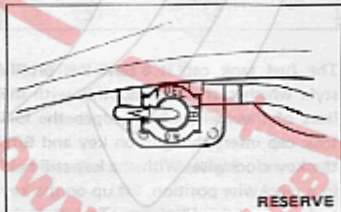
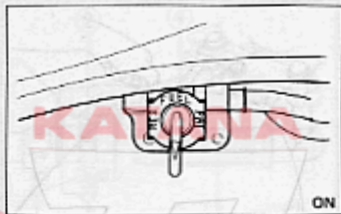

This motorcycle is equipped with an automatic type, diaphragm style fuelcock. There are three (3) positions: "ON", "RESERVE" and "PRIME".

"ON" The normal position for the fuelcock lever is on the "ON" position. In this position, no fuel will flow from the fuelcock to the carburetor unless the engine is running or being started.

"RESERVE"

If the fuel level in the tank is too low, turn the lever to the "RESERVE" position to use the 5.0 liters (5.3/4.4 US/Imp qt) of the reserve fuel supply. In this position, no fuel will flow from the fuelcock to the carburetor unless the engine is running or being started.

"PRIME"

If the motorcycle has run out of fuel or has been stored for an extended period, there may not be any gasoline in the carburetors. In this instance the fuelcock lever should be moved to

the "PRIME" position. This will allow the fuel to flow directly into the carburetors even though the engine is not operating. Upon starting the engine, be sure to return the lever to the "ON" position or, if necessary, to the "RESERVE" position.

CAUTION:

Leaving the fuelcock in the "PRIME" position may cause the carburetors to overflow and fuel to run into the engine. It is possible that this may cause severe mechanical damage when the engine is started.

NOTE: After switching the fuel tank supply to the "RESERVE" position, it is advisable that the tank be refilled at the closest gas station. After re-fueling, be sure to move the fuelcock to the "ON" position.

GEARSHIFT LEVER

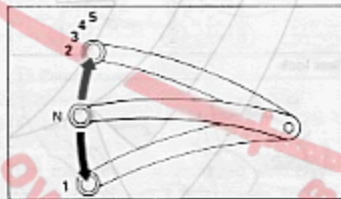

This motorcycle is equipped with a 5-speed constant mesh transmission which operates as shown in the figure. The shift lever is attached to a ratchet type mechanism in the transmission. Each time that a gear is selected, the gear shift lever will return to its normal position ready to select the next gear. Neutral is located between low and 2nd gear. Low gear is engaged by depressing the lever down-

ward from the neutral position. Shifting into the higher gears is accomplished by lifting up on the shift lever once for each gear. It is not possible to up shift or down shift more than one gear at a time due to the ratchet mechanism being used. When shifting from low to 2nd gear or 2nd gear to low, neutral will be automatically skipped. When neutral is desired, depress or lift the lever to a position halfway between low and 2nd gear.

CAUTION:

When the transmission is in neutral the green indicator light on the instrument panel will be lit. However, even though the light is illuminated, cautiously release the clutch lever slowly to determine whether the transmission is positively in neutral.

Reduce your road speed before downshifting. When down shifting, the engine RPM's should be increased before the clutch is engaged. This will prevent unnecessary wear on the drivetrain components and rear tyre.

REAR BRAKE PEDAL

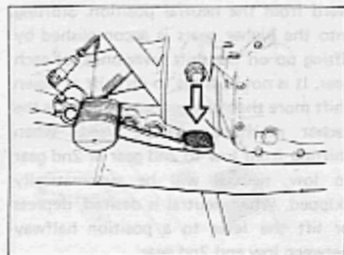

Depressing the rear brake pedal will apply the rear disc brake. The brake light will be illuminated when the rear brake is operated.

SEAT LOCK



Seat lock

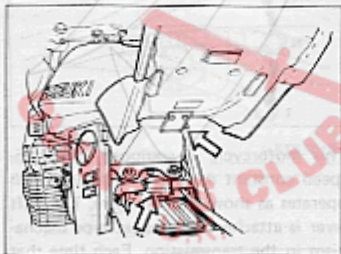

Seat holding hooks

The seat lock is located behind the seat. To open the seat, insert the ignition key into the lock and turn the key clockwise until the lock is released. Raise and slide back the seat by hand and unhook the seat hooks from the seat holding hooks. To lock the seat, push down firmly until the seat latch snaps into the locked position.

HELMET HOLDER

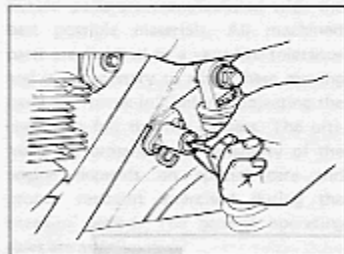

Use helmet holder in this manner. Insert the key, twist it clockwise to open the latch, hook your helmet fastener ring to the latch and twist the key back to lock the holder.

WARNING:

Do not operate the motorcycle with a helmet fastened to the helmet holder. The helmet may be caught in the wheel causing an accident, or interfere with the safe operation of the motorcycle.

STANDS

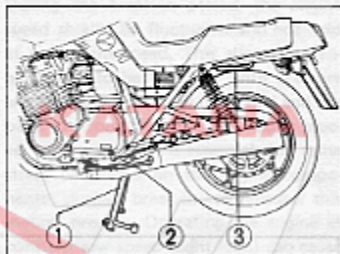

- ① Center stand
- ② Side stand
- ③ Lift bar

The motorcycle is equipped with both a center stand and a side stand. To place the motorcycle on the center stand, place your foot firmly on the stand extension and then rock the motorcycle to the rear and upward with the lift bar with your right hand, while steadying the handlebars with your left hand.

WARNING:

Before starting off, check that the side stand is returned to its normal up position and is not hanging down.

FUEL AND OIL RECOMMENDATION

FUEL

Use gasoline with an octane number of 90 or higher (Research Method), preferably unleaded or low-lead.

NOTE: Unleaded and low-lead gasoline will extend spark plug life.

ENGINE OIL

Using a premium quality four stroke motor oil will increase the service life of your motorcycle. Use only oils which are rates SE or SD under the API classification system. The viscosity rating should be SAE 10W-40. If an SAE 10W-40 motor oil is not available, select an alternative according to the chart below.

SAE	40							
	30							
	20W-50							
	10W-50							
	10W-30							
	20W							
	10W							
Temperature								
	$^{\circ}\text{C}$	-20	-10	0	10	20	30	40
	$^{\circ}\text{F}$	-4	14	32	50	68	86	104

Suzuki parts are manufactured with the best possible materials. All machined parts are finished to a very fine tolerance and it is necessary to allow these moving parts to "break-in" before subjecting the engine to full throttle stresses. The ultimate performance and reliability of the engine depends on special care and proper restraint exercised during the break-in period. The general operating rules are as follows:

During the break-in period, the engine speed should be fluctuated and not held at a constant speed. This allows the engine parts to be "loaded" with pressure and then the pressure is decreased and the parts can cool. This aids the mating process of the parts. It is essential that some stress be placed on the engine components during break-in to ensure this mating process. Operating the engine at constant low speed (light load) can cause the parts to glaze and not seat properly. After the engine has been operated for 1 600 km (1 000 miles), the motorcycle can be subjected to full throttle operation for short periods of time. Under no circumstances should the engine red line of 9 000 r/min be exceeded.

Initial 800 km (500 miles)	Below 4 000 r/min
Up to 1 600 km (1 000 miles)	Below 6 000 r/min
Over 1 600 km (1 000 miles)	Below 9 000 r/min

Before riding the motorcycle, be sure to check the following items. Never underestimate the importance of these checks and perform all of them before riding the machine.

WHAT TO CHECK	CHECK FOR:
Steering	1) Smoothness 3) No play or looseness
Brakes	2) No restriction of movement 1) Corrected pedal and lever play 3) No fluid leakage
Tyres	2) Adequate tread depth 1) Correct pressure 3) No cracks or cuts
Fuel	Enough fuel for the planned distance of operation
Lighting	Operation of all lights – HEADLIGHT, TAILLIGHT, BRAKE LIGHT, LICENSE PLATE LIGHT, INSTRUMENT LIGHTS, TURN SIGNALS
Indicator Lights	Oil pressure, High beam, Neutral, Turn signal
Horn and "Kill Switch"	Correct function
Engine Oil	Correct level
Throttle	1) Correct play in the throttle cable 2) Smooth operation and positive return of the throttle grip to the closed position
Clutch	1) Correct play in the cable 2) Smooth and progressive action
Drive Chain	1) Correct tension or slack 2) Adequate lubrication

STARTING THE ENGINE

Check that the fuelcock lever is in the "ON" position and that the engine kill switch is in the "RUN" position. Insert the ignition key into the ignition switch and turn it clockwise one notch to the "ON" position. The neutral indicator light will light if the transmission is in neutral.

CAUTION:

Always start the engine with the transmission in neutral, the clutch lever pulled in, and the rider in the normal riding position.

When the engine is cold:

Pivot the carburetor choke lever all the way to the "ON" position. Close the throttle completely. Push the electric starter button and the engine will start. Immediately after the engine starts, keep the engine revolutions to a maximum of 2 000 r/min by using the choke lever position for throttle control. Return the choke lever all the way back to its normal disengaged position approximately 50 seconds after the engine starts. In ex-

tremely cold weather it may be necessary to use the choke longer than 50 seconds.

When the engine is warm:

Open the throttle 1/8th to 1/4th turn and push the electric starter button. Operation of the carburetor choke system is usually not necessary when the engine is warm.

WARNING:

Do not run the engine indoors where there is little or no ventilation available. Carbon monoxide fumes are extremely poisonous. Never leave the motorcycle running while unattended, even for a moment.

STARTING OFF

Pull the clutch lever in and pause momentarily. Engage first gear by depressing the gear shift lever downward. Twist the throttle grip toward you and at the same time release the clutch lever gently and smoothly. As the clutch engages, the motorcycle will start moving forward.

To shift to the next higher gear, accelerate gently, then close the throttle and pull the clutch lever in simultaneously. Lift the gear shift lever upward to select the next gear and release the clutch lever and open the throttle again. Select the gears in this manner until top gear is reached.

USING THE TRANSMISSION

The transmission is provided to keep the engine operating smoothly in its normal operating speed range. The gear ratios have been carefully chosen to meet the characteristics of the engine. The rider should always select the most suitable gear for the prevailing conditions. Never slip the clutch to control road speed, but rather downshift to allow the engine to run within its normal operational range.

RIDING ON HILLS

— When climbing steep hills, the motorcycle may begin to slow down and "lug" the engine excessively. At this point you should shift to a lower gear so that the engine will again be operating in its normal power range. Shift

rapidly to prevent the motorcycle from losing momentum.

- When riding down a hill, the engine may be used for braking by shifting to a lower gear.
- Be careful, however, not to allow the engine to over rev.

WARNING:

- (1) If this is the first time that you have ridden a machine of this type, we suggest that you practice on a non-public road to become thoroughly familiar with the controls and operation of the motorcycle.
- (2) Before starting off, always return the side stand to its normal "up" position.
- (3) Slow down to a safe speed before negotiating a corner.
- (4) Don't down shift in the midst of cornering.
- (5) One-hand riding is extremely dangerous. Keep both hands firmly on the handlebars and both feet securely on the foot rests. Under no circumstances

should both hands be removed from the handlebars.

USING THE BRAKES AND PARKING

- Twist the throttle grip away from yourself to close the throttle completely.
- Apply the front and rear brakes evenly and at the same time.
- Downshift through the gears as road speed decreases.
- Select neutral with the clutch lever squeezed towards the grip (disengaged position) just before the motorcycle stops. Neutral position can be confirmed by observing the neutral indicator light.

NOTE: Inexperienced riders tend to use the rear brake only. This can lead to premature brake wear and excessive stopping distances.

WARNING:

Using only the front or rear brake is dangerous and can cause skidding and loss of control.

- Apply the brakes lightly and with great care on a wet highway pavement or other slippery surfaces and at all corners. Any abrupt braking on slippery or irregular roads can be particularly dangerous.
- If the motorcycle is to be parked on the side stand and on a slight slope, you may wish to leave the motorcycle in 1st gear to prevent it from rolling off of the side stand. Return to neutral before starting engine.
- Turn the ignition switch to the "OFF" position to stop the engine.
- Remove the ignition key from the switch.
- Lock the steering for security.

HIGH SPEED RIDING

High speed riding requires that certain adjustments be made to the suspension system of the motorcycle to increase the stability. Tyre pressures should also be increased for high speed riding as described on page 49.

CAUTION:

Never allow the engine to exceed 9,000 rpm in any gear.

WARNING:

High speed cruising requires special care. Be sure that you review the pre-ride instruction chart and that your machine is in top condition. Do not exceed the legal speed limits.

CLOTHING

Proper motorcycle riding starts with proper clothing.

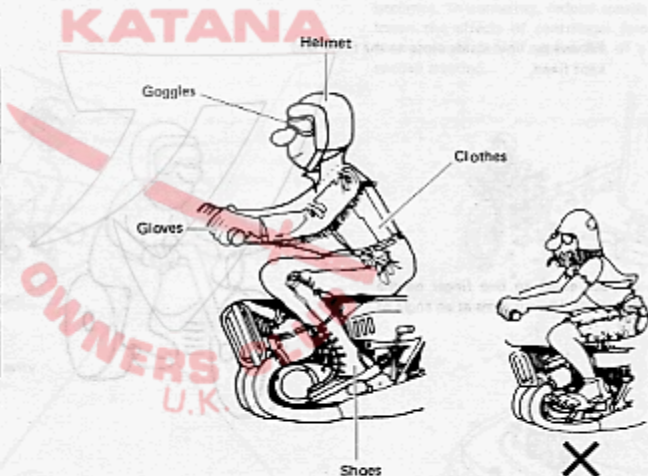

POSTURE

Proper motorcycle riding starts with proper posture.

Elbows are held inside close to the body and kept fixed.

Look widely instead of gazing at one point.

Leave a space equal to one finger on the inside (front). Hold your arms at an angle of about 120° .

Relax to guard against a sudden impact.

Hips are in a position to relax arms and shoulders.

Press the tank tightly on rough roads.

Toes point straight ahead.



KATANA

OWNER'S CLUB
U.K.

CORNERING

When cornering, centrifugal force works in a direction perpendicular to the direction in which the motorcycle is moving.

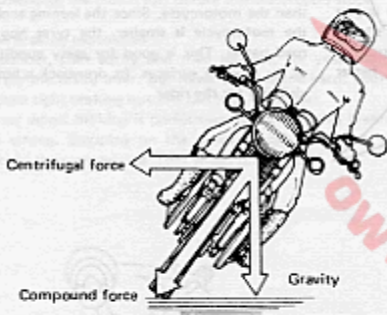

Centrifugal force increases in proportion to a square of the speed of the machine, and the shorter the radius of the corner, the greater it becomes. In cornering, reduce speeds so as to lessen the effects of centrifugal force. By all means, avoid abrupt application of a brake or sudden steering.



GOOD CORNERING

There are three basic postures in leaning the motorcycle. It is an important step to safe riding to master the three basic cornering postures and choose between them for different cornering situations.

Lean-with

The body of the rider is leaned at the same angle as the motorcycle. This is a natural and stable posture for cornering. Its feature is stability because the posture is kept in balance while cornering.



Lean-out

This posture holds the upper part of the body upright as if pushing the motorcycle down inside. The motorcycle lean angle is the largest of the three. The upper part of the rider's body held upright gives stability — a good posture for beginners. It gives maneuverability, better visibility, and control on rough roads.



Lean-in

This is the posture to bend the upper part of the body farther inside at a larger leaning angle than the motorcycle. Since the leaning angle of the motorcycle is smaller, the tyres hug the road better. This is good for rainy conditions or for slippery surfaces. Its drawback is limited visibility for the rider.



KATANA
OWNERS CLUB

BRAKING

For safe riding it is very important to master the braking techniques.

Points to note in braking:

1. Hold the motorcycle upright as you stop it.
2. Avoid abrupt braking.
3. Depress the pedal in several motions ("pumping") instead of one single motion, keeping the approaching vehicles informed.
4. Disengage the clutch just before the motorcycle stops.

Good braking techniques

Remember, start softly and then squeeze, for your right hand to operate the brake lever. But never squeeze too hard: your hand can produce tight braking but this can lock the wheel.

As rear wheel braking is performed by the toe, this braking can be very strong. Stepping on the pedal quickly can lock the wheel. Brake in the same way as front wheel braking.

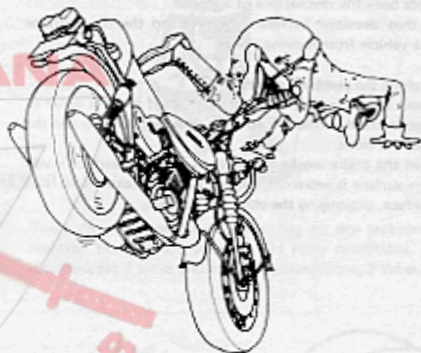

Process of vehicle coming to a stop

1. Friction that develops between the brake shoes and the brake drum holds back the revolutions of a wheel.
2. Friction that develops between the tyre and the road surface prevents a vehicle from moving ahead.

Causes to prolong the stopping distance

1. If the brake shoes or drum are worn out, or if there is water or oil leakage in them, sufficient friction does not develop and the brake does not work.
2. Even when the brake works normally, if the road surface is wet or the tyre surface is worn off, friction does not take a firm hold on the surface, prolonging the stopping distance.



OWNERS CLUB
U.K.

REACTION TIME

It is about 0.5 seconds before the brake is applied after the motorcycle rider reacts to the sign of danger. This is called "reaction time."

During the reaction time, the machine is moving at the same speed as before the rider reacts to a danger sign and applies the brake. Reaction time varies according to individuals. But the faster the speed, the longer the distance it takes for the rider to react and take action at a danger sign. So it is very important to be careful when riding at high speeds.

RELATION BETWEEN SPEEDS AND STOPPING DISTANCES IN GENERAL

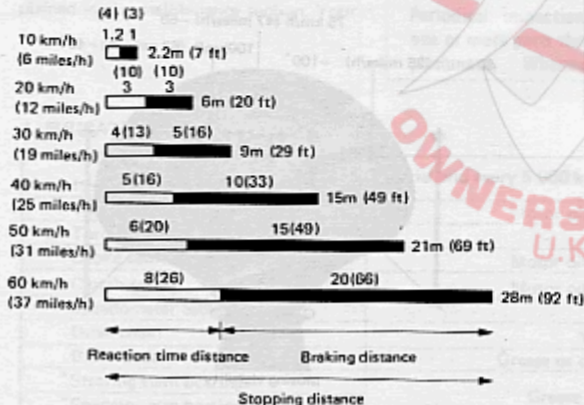

These distances are for careful riding on dry asphalt roads with a reaction time of 0.5 seconds. For rainy conditions, the stopping distances are 2 times and for snowy conditions, 3 times.

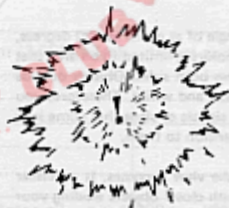

VISION

Human senses can adjust themselves to the speeds of man's activities, and they are not made to the speeds of a motor vehicle. Therefore, high speeds are likely to cause illusions and distortions in human senses. Decreasing vision is most likely to cause an accident. So it is important to ride at reasonable speeds.

Moving Vision

Moving vision refers to vision in relation to a moving object or the vision of an observer while in motion.

Note that it is lower than still vision in which still object are recognizable, and note, too, that it decreases in proportion to speed as indicated below:

Decreasing rates of vision

Speeds	Vision
0	1.2
10 km/h (6 miles/h)	1.0
29 km/h (18 miles/h)	0.8
54 km/h (34 miles/h)	0.7
72 km/h (45 miles/h)	0.6

VISIBILITY

While one's visibility extends at an angle of as much as 200 degrees, the area in which one can recognize colors is limited to an area that extends 35 degrees from the center on both sides. Objects outside of that area are perceived only in black and white. Therefore, you cannot recognize properly the traffic signals or signs that come into that area unless you pay particular attention to them.

Moving visibility

The faster you move, the narrower the view becomes. It is similar to looking through a pipe or a tube, with closer objects eluding your vision and the view limited only to those farther in sight. This is an effect of moving visibility and it begins to occur with a speed of about 40 km/h (25 miles/h). The faster you ride, the farther into the distance you have to look.

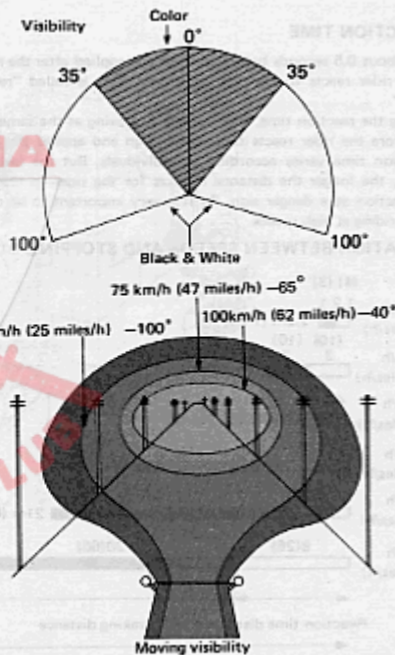

PERIODIC MAINTENANCE SCHEDULE

MAINTENANCE SCHEDULE

The chart indicates the intervals between periodic services in miles (kilometers) and months. At the end of each interval, be sure to inspect, check, lubricate and service as instructed. If your motorcycle is used under high stress conditions such as continuous full throttle operation, or is operated in a dusty climate, certain services should be performed more often to insure reliability of the machine as explained in the maintenance section. Your

Suzuki dealer can provide you with further guidelines. Steering components, suspension and wheel components are key items and require very special and careful servicing. For maximum safety we suggest that you have these items inspected and serviced by your authorized Suzuki dealer.

CAUTION:

Periodical inspections may reveal one or more parts that may need replacement. Whenever replacing

parts on your motorcycle, it is recommended that you use Genuine Suzuki replacement parts or their equivalent. Whether you are an expert or do-it-yourself mechanic, Suzuki recommends that those items on the Inspection Chart marked with an asterisk (*), be performed by your authorized Suzuki dealer. You may perform the unmarked items easily by referring to the instructions in this section.

LUBRICATION CHART

Item	Interval	Initial and every 5 000 km (3 000 miles)	Initial and every 10 000 km (6 000 miles)
Throttle cable		Motor oil	—
Throttle grip		—	Grease
Choke cable		Motor oil	—
Clutch cable		Motor oil	—
Speedometer cable		—	Grease
Drive chain		Motor oil every 1 000 km (600 miles)	
Brake pedal		Grease or oil	—
* Steering stem bearings		Grease every 2 years or 20 000 km (12 000 miles)	
* Swinging arm bearings			

MAINTENANCE CHART
ENGINE

Interval \ Item	Initial 1 000 km (600 miles)	Every 5 000 km (3 000 miles)	Every 10 000 km (6 000 miles)
Battery	Inspect	Inspect	—
* Engine bolts and nuts	Inspect	Inspect	—
Air cleaner	Clean every 3 000 km (2 000 miles), and replace every 12 000 km (8 000 miles)		
* Valve clearance	Inspect	Inspect	—
* Compression	Inspect	Inspect	—
Spark plug	Inspect	Inspect	Replace
Carburetor	Inspect	Inspect	—
* Fuel lines	Replace every 2 years		
Engine oil	Change	Change	—
Engine oil filter	Replace	Replace	—
* Oil pressure	—	Inspect	—
* Oil sump filter	—	—	Clean
Clutch	Inspect	Inspect	—

CHASSIS

Interval \ Item	Initial 1 000 km (600 miles)	Every 5 000 km (3 000 miles)	Every 10 000 km (6 000 miles)
Drive chain	Inspect and clean every 1 000 km (600 miles)		
Brakes	Inspect	Inspect	—
* Brake hose	Replace every 2 years		
* Brake fluid	Change every 1 year		
Tyres	Inspect	Inspect	—
* Steering	Inspect	Inspect	—
* Front fork oil	Change	—	Change
* Bolt and nut	Inspect	Inspect	—

TOOLS

To assist you in the performance of periodic maintenance, a tool kit is supplied and is located in the rear tail section under the seat. The tool kit consists of the following items.

Ref. No.	Item
1.	Tool Bag
2.	8mm Open End Wrench
3.	10 x 12mm Open End Wrench
4.	14 x 17mm Open End Wrench
5.	Spark Plug Socket Wrench
6.	19mm Ring Wrench
7.	27mm Ring Wrench
8.	Ring Wrench Handle
9.	Socket Wrench Handle
10.	Combination Screwdriver
11.	Cross Head Screwdriver
12.	Screwdriver Handle
13.	Pliers
14.	L Type Hexagon Wrench

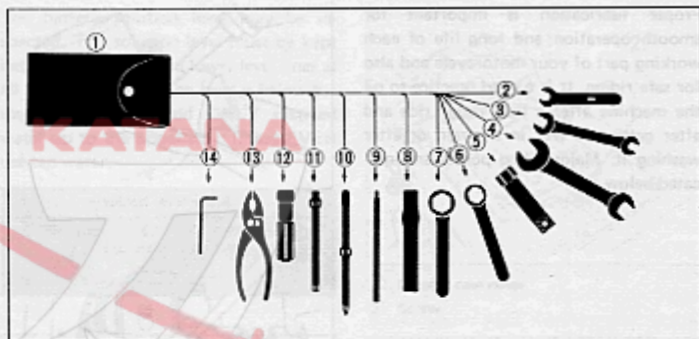

OILING CHART

Proper lubrication is important for smooth operation and long life of each working part of your motorcycle and also for safe riding. It is a good practice to oil the machine after a long rough ride and after getting it wet in the rain or after washing it. Major oiling points are indicated below.

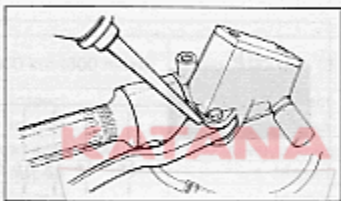

Brake lever holder

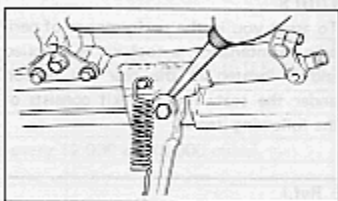

Side stand pivot

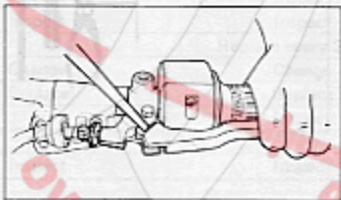

Clutch lever holder

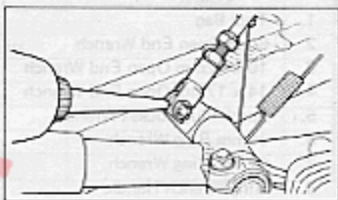

Rear brake rod link

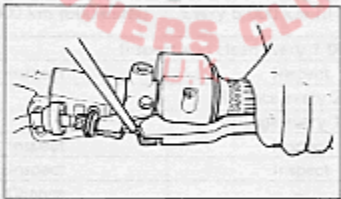

Clutch cable

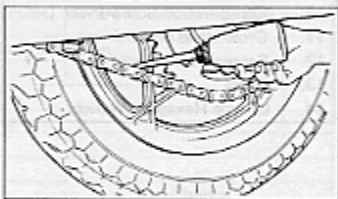

Drive chain

BATTERY

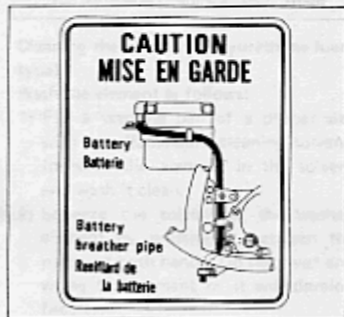
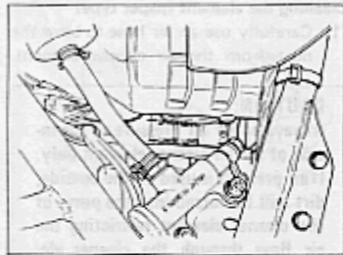

The battery solution level may be inspected. The solution level must be kept between the upper and lower level lines at all times. If the solution level is below the lower limit line, add **ONLY** distilled water up to the upper limit line. **NEVER** use tap water.

WARNING:

Once the battery has been initially serviced, **NEVER** add diluted sulphuric acid.

CAUTION:

Be careful not to bend, obstruct, or change the routing of the air vent tube from the battery. Make certain that the vent tube is attached to the battery vent fitting and that the opposite end is always open.

AIR CLEANER

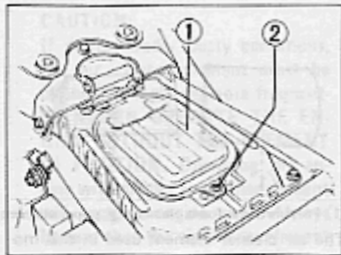

- ① Cleaner case cover
- ② Screw

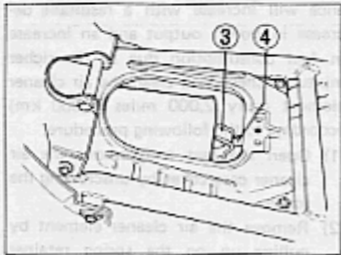

- ③ Spring retainer bracket
- ④ Spring

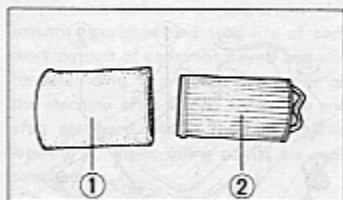

① Polyurethane foam element ② paper element

The air cleaner element used in this motorcycle is both polyurethane foam and paper type element. If the element has become clogged with dust, intake resistance will increase with a resultant decrease in power output and an increase in fuel consumption due to the richer mixture. Check and clean the air cleaner element every 2,000 miles (3,000 km) according to the following procedure.

- (1) Open the seat and remove the air cleaner case cover by unscrewing the screw.
- (2) Remove the air cleaner element by pulling up on the spring retainer bracket.
- (3) Draw out the polyurethane foam element from the air cleaner.



Cleaning the element (paper type)

- (1) Carefully use an air hose to blow the dust from the air cleaner element.

CAUTION:

Always apply air pressure to the inside of the air cleaner element only. If air pressure is used on the outside, dirt will be forced into the pores of the cleaner element restricting the air flow through the cleaner element.

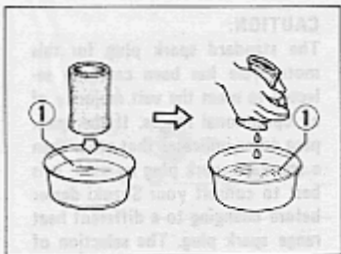

① Non flammable cleaning solvent.

Cleaning the element (Polyurethane foam type)

Wash the element as follows:

- 1) Fill a washing pan of a proper size with non-flammable cleaning solvent. Immerse the element in the solvent and wash it clean.
- 2) Squeeze the solvent of the washed element by pressing it between the palms of both hands: Do not twist and wring the element or it will develop fissures.

CAUTION:

Don't apply oil to the spongy. After washing, dry it up completely and install.

CAUTION:

Before and during the cleaning operation, carefully examine the element for any tears in the material. A torn element must be replaced with a new one.

- (3) Reinstall the cleaned element or new air cleaner element in reverse order of removal, taking care to make sure that the spring bracket is properly engaged with the securing spring. Be absolutely sure that the element is securely in position and is sealing properly. Replace the air cleaner element with a new one every 7,500 miles (12,000 km).

CAUTION:

If driving under dusty conditions, the air cleaner element must be cleaned or replaced more frequently. **NEVER OPERATE THE ENGINE WITHOUT THE ELEMENT IN POSITION.** Operating the engine without the air cleaner element will increase engine wear. Always be sure that the air cleaner element is in excellent operational condition at all times. The life of the engine depends largely on this single component.

SPARK PLUGS

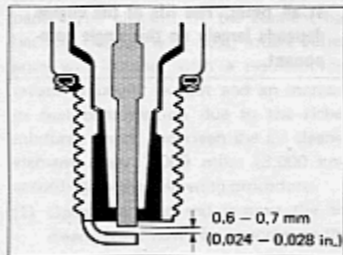
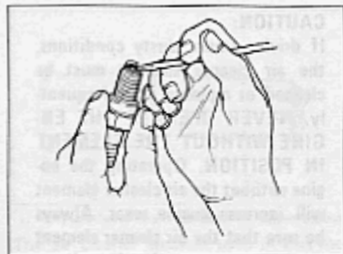

The standard plug for this motorcycle is as shown below. If the standard spark plug is unsuitable for your usage, that is, apt to overheat (porcelain shows whitish appearance), or get wet (black appearance), change it as follows.

A spark plug heavily carboned or otherwise fouled will not produce strong sparking. Remove carbon deposits with a wire or pin and adjust the spark plug gap to 0.6 - 0.7 mm (0.024 - 0.028 in.) for NGK and NIPPON DENSO by measuring with a thickness gauge.

Plug replacement guide

- *I For general market, Australia and Singapore.
- *II For England and South Africa.

NGK		NIPPON DENSO		REMARKS
*I	*II	*I	*II	
D7EA	DR7ES	X22ES-U	X22ESR-U	If the standard plug is apt to get wet, replace with this plug.
D8EA	DR8ES-L	X24ES-U	X24ESR-U	Standard
D9EA	DR8ES	X27ES-U	X27ESR-U	If the standard plug is apt to overheat, replace with this plug.

CAUTION:

The standard spark plug for this motorcycle has been carefully selected to meet the vast majority of all operational ranges. If the spark plug color indicates that other than a standard spark plug be used, it is best to consult your Suzuki dealer before changing to a different heat range spark plug. The selection of an improper spark plug can lead to severe engine damage. Selecting another brand of spark plug other than NGK or Nippon Denso, may also lead to operational difficulties. You should consult your authorized Suzuki dealer before selecting an alternate brand.

ENGINE OIL

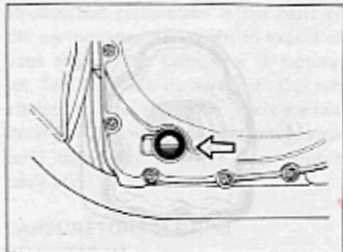

Engine oil inspection window

Superior engine life depends much on the selection of quality oil and the periodic changing of the oil. Daily oil level checks and periodic changes are two of the most important maintenances to be performed.

CAUTION:

Never operate the motorcycle if the engine oil level is below the "L" (low) line in the inspection window. Never fill the engine oil level above the "F" (full) line.

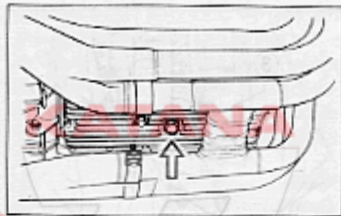

Drain plug

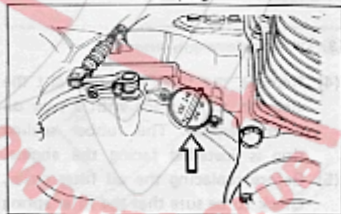

Oil filler cap

ENGINE OIL CHANGE (Without Filter Change)

Change the engine oil periodically. The oil should always be changed when the engine is hot so that the oil will drain thoroughly from the engine. The procedure is as follows:

- (1) Place the motorcycle on the center stand.
- (2) Remove the oil filler cap.
- (3) Drain the oil by removing the drain plug from the bottom of the engine.
- (4) Replace the drain plug and tighten securely after all the oil has been drained out. Add fresh oil through the filler hole. Approximately 3,200 ml (3.4/2.8 US/Imp qt.) of oil will be required.
- (5) Start the engine and allow it to idle for several seconds.
- (6) Turn the engine off and wait approximately one (1) minute, then recheck the oil level in the engine oil inspection window. The oil level should be at the "F" mark. If lower than the "F", add oil until it reaches the "F" mark.

CAUTION:

Be sure to always use the specified engine oil described on page 18.

ENGINE OIL AND FILTER CHANGE

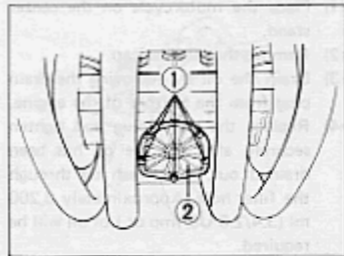

① Nut ② Filter cap

- (1) Place the motorcycle on the center stand.
- (2) Drain the engine oil by removing the drain plug from the bottom of the engine.
- (3) Remove the five nuts holding the filter cap in place.

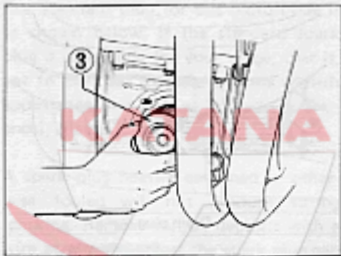

③ Oil filter element

- (4) Remove the filter cap, pull out the element and replace with a new oil filter element. The rubber sealing ring is installed facing the engine.
- (5) Before replacing the oil filter cover, check to be sure that the filter spring and the cap "O" ring are installed correctly.
- (6) Replace the oil filter cover and tighten the nuts securely.
- (7) Replace the drain plug and tighten them securely. Add fresh oil through the filler hole approximately 3,600 ml (3.8/3.2 US/Imp qt.) will be required.

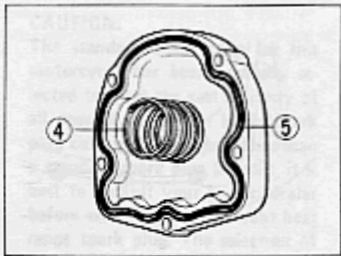

④ Spring ⑤ "O" ring

- (8) Start the engine and allow it to idle for several seconds.
- (9) Turn the engine off and wait approximately one minute, then recheck the oil level in the engine oil inspection cover. The oil level should be at the "F" mark. If lower than the "F" mark, add oil until it reaches the mark.

CAUTION:

Be sure to always use the specified engine oil described on page 18.

CARBURETOR

Undisturbed carburetion is the basis of the performance you ought to expect of your engine. The carburetor is factory-set for the best carburetion. Do not attempt to alter its setting. There are two items of adjustment, however, under your care: carburetor idle rpm and throttle cable play.

CARBURETOR IDLE RPM ADJUSTMENT

- (1) Start up the engine and warm it up by running it at 2,000 rpm for 10 minutes in summer (where ambient temperature is 30°C (86°F) or thereabout) or for 20 minutes in winter (where ambient temperature is down to -5°C (23°F) or thereabout).
- (2) After engine warms up, turn the throttle stop screw located on the carburetor in or out so that engine may run at 950-1,150 rpm.

CAUTION:

The carburetor idle rpm should be adjusted after the engine warms up.

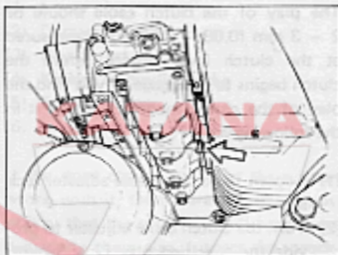

Throttle stop screw

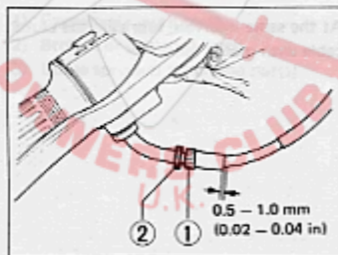

- ① Throttle cable adjuster
- ② Lock nut

THROTTLE CABLE ADJUSTMENT

- 1) Loosen lock nut.
- 2) Adjust the cable slack by turning adjuster in or out to obtain the correct slack 0.5 - 1.0 mm (0.02 - 0.04 in).
- 3) After adjusting the slack, tighten the lock nut.

CLUTCH ADJUSTMENT

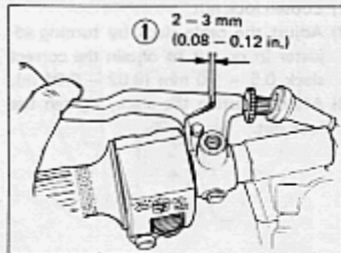

① Play

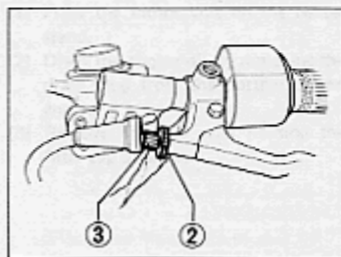

② Lock nut
③ Cable adjuster

The play of the clutch cable should be 2 - 3 mm (0.08 - 0.12 in) as measured at the clutch lever holder before the clutch begins to disengage. If you find the play of the clutch incorrect, adjust it in the following way:

- (1) Loosen the clutch cable adjuster lock nut.
- (2) Turn the clutch cable adjuster to provide the specified play (2 - 3 mm).
- (3) Tighten the lock nut.

At the same intervals, lubricate the clutch cable with motor oil.

CAMSHAFT DRIVE CHAIN TENSIONER

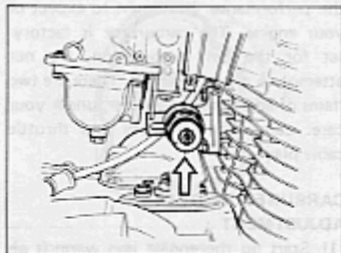

The camshaft drive chain is kept in proper adjustment by an AUTOMATIC camshaft drive chain tensioner. This automatic tensioner never needs servicing by the customer and the camshaft drive chain itself need not be checked for stretch or wear.

CAUTION:

Never attempt to turn the tensioner wheel in either direction. Turning the wheel even slightly can jam the mechanism which will prevent it from adjusting the chain properly. An improperly adjusted chain can cause severe engine damage.

DRIVE CHAIN

This motorcycle is equipped with a special drive chain. It is an endless type that does not use a master link. We recommend that you take your motorcycle to your authorized Suzuki dealer to have the drive chain replaced when it becomes worn.

The drive chain is also constructed of special materials and has grease permanently sealed inside it by the use of special sealing "O" rings.

WARNING:

For maximum safety, the drive chain condition and adjustment should be checked prior to operating the motorcycle. Always follow the manufacturer's recommendations for replacement and for proper lubrication.

At the periodic inspections, the drive chain should be inspected for the following conditions.

- (1) Loose pins
- (2) Damaged rollers
- (3) Dry or rusted links
- (4) Kinked or binding links
- (5) Excessive wear
- (6) Improper chain adjustment

If the drive chain has any of these items wrong with it, then there is a strong possibility that the sprockets will have some damage to them also. Inspect the sprockets for the following:

- (1) Excessively worn teeth
- (2) Broken or damaged teeth
- (3) Loose sprocket mounting nut(s)

DRIVE CHAIN CLEANING AND OILING

Grease is permanently sealed inside the rollers of this motorcycle chain by the use of special "O" rings. At intervals of 600 miles (1,000 km) clean and oil the chain, as follows:

- (1) Cleaning the chain with kerosene is strongly recommended. If the chain tends to rust, the interval must be shortened. Kerosene is a petroleum product and will provide some lubrication as well as cleaning action.

CAUTION:

Do not use gasoline, trichlene or other commercial cleaning solvents. These fluids have a strong dissolving power that could damage the "O" rings in the chain. This will allow the grease to run out of the chain and the chain would have to be replaced.

CHAIN ADJUSTMENT

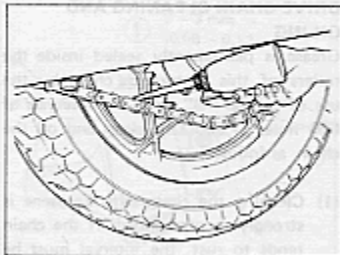

- (2) Oiling the chain. After thoroughly washing the chain and allowing it to dry, oil the links with a heavy weight motor oil 40 or 50 weight.

CAUTION:

Do not use any oil sold commercially as drive chain oil. These oils contain solvents and additives which could damage the "O" rings in the chain.

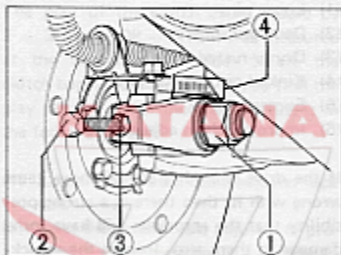

- ① Axle nut
- ② Chain adjuster bolt
- ③ Lock nut
- ④ Reference mark

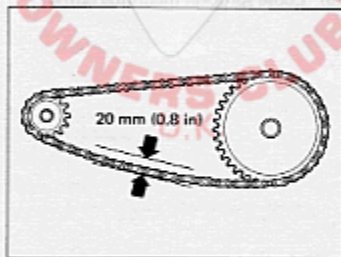

ADJUSTING DRIVE CHAIN

Adjust the drive chain to the proper specification. The chain may require more frequent adjustments depending upon your riding conditions.

WARNING:

These recommendations are the maximum intervals between the adjustment periods. The drive chain adjustment should be checked every time that the machine is operated. Excessive chain slack could cause the chain to come off the sprockets and result in an accident or serious engine damage. To adjust the drive chain, follow these directions:

- (1) Place the machine on the center stand.
- (2) Loosen the axle nut.

- (3) Loosen the lock nuts.
- (4) Adjust the slack in the drive chain by turning the right and left chain adjuster bolts in after loosening the lock nut. At the same time that the chain is being adjusted, the rear sprocket must be kept in perfect alignment with the front sprocket. To assist you in performing this procedure, there are reference marks on the swing arm and each chain adjuster which are to be aligned with each other and to be used as a reference from one side to the other. After aligning and adjusting the slack in the drive chain to 20 mm (0.8 in.) retighten the axle nut securely. Tighten the chain adjuster lock nuts and chain adjuster support bolts and perform a final inspection.

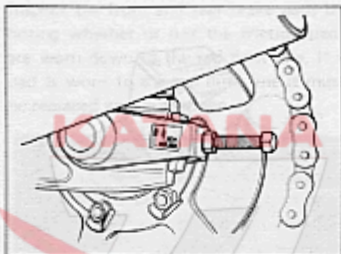

CAUTION:

Never allow the drive chain slack to exceed 50 mm (2 in.). If the slack is allowed to be greater than this figure, the chain may come off the sprockets and cause severe engine damage or an accident. When the indicator mark on the chain adjuster aligns with the end of the swing arm, the drive chain should be replaced with a new one as it has become worn excessively. Refer to the drive chain information label on the chain guard.

CAUTION:

The drive chain for this motorcycle is made of a special material. The chain should be replaced with either a DAIDO DID630YL or a TAKASAGO RK630GSV. Use of another chain may lead to premature chain failure.

NOTE: The two sprockets should be inspected for wear when a new chain is installed and replaced if necessary.

BRAKES

This motorcycle utilizes front and rear disc brakes. Properly operating brake systems are vital to safe riding. Be sure to perform the brake inspection requirements as scheduled. The brakes should be inspected at the initial 600 miles (1,000 km) inspection and every 3,000 miles (5,000 km) thereafter, by your authorized Suzuki dealer.

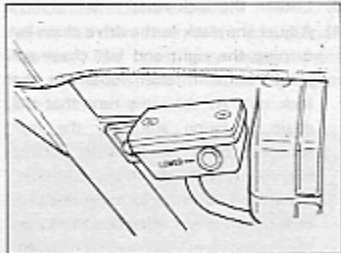
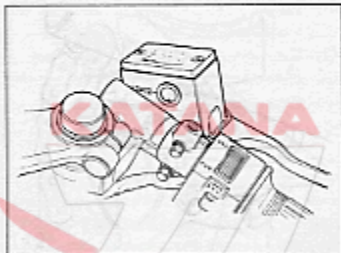

BRAKE FLUID

WARNING:

Brake fluid may be harmful if swallowed or if it comes in contact with skin or eyes. Contact your physician immediately. If swallowed induce vomiting. If brake fluid gets into the eyes or in contact with the skin, it should be flushed thoroughly with plenty of water.

CAUTION:

This motorcycle uses a glycol-based brake fluid. Do not use or mix different types of brake fluid such as silicone-based or petroleum-based fluid, otherwise serious damage will result to the brake system. Never use any brake fluid that has been stored in a used or unsealed container. Never reuse brake fluid that has been stored in a used or unsealed container. Never reuse brake fluid left over from the last servicing and stored for long periods as it absorbs moisture from

the air. Use only SAE J1703 brake fluid. Do not spill any brake fluid on painted or plastic surfaces as it will damage the surface severely.

Be sure to check the brake fluid level in the front and rear reservoirs. If the level is found to be lower than the lower mark, replenish with brake fluid that meets Suzuki's requirements. As the brake pads wear, the fluid level will drop to compensate for the new position of the brake pads. Replenishing the brake fluid reservoir is considered normal periodic maintenance.

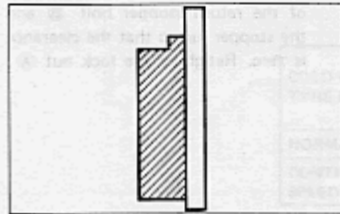
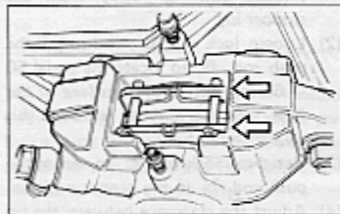
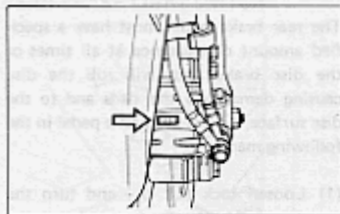

Inspect the front and rear brake pads by noting whether or not the friction pads are worn down to the red limit line. If a pad is worn to the red limit line it must be replaced with a new one.

WARNING:

If the brake system or pads need to be repaired or serviced we strongly advise you to have your authorized Suzuki dealer perform service. He has the proper tools and proper training to perform the job in a safe and economical manner.

CAUTION:

Disc brake systems operate under extremely high pressures. For safety, the brake hose and brake fluid should be changed at intervals of no longer than two (2) years. Inspect your brake system for the following items daily.

- (1) Inspect the front and rear brake system for signs of fluid leakage.
- (2) Inspect the brake hose for leakage or a cracked appearance.
- (3) The brake lever should have the proper stroke and be firm at all times.
- (4) Check the wear of the disc brake pads.

OWNERS CLUB
U.K.

FRONT BRAKE LIGHT SWITCH

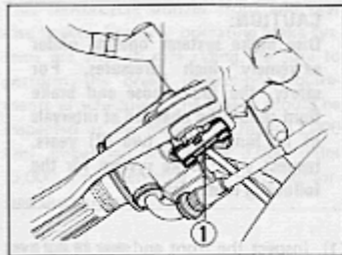

The front brake light switch ① is located beneath the front brake lever. Loosen the switch fitting screws and adjust the actuating point by moving the switch body to the right or to the left so that the brake light will come on just before a pressure rise is felt at the lever.

REAR BRAKE PEDAL ADJUSTMENT

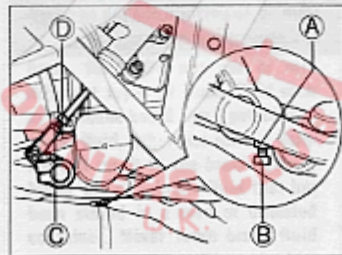
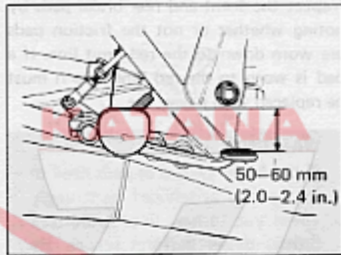

The rear brake pedal must have a specified amount of clearance at all times or the disc brake pads will rub the disc causing damage to the pads and to the disc surface. Adjust the brake pedal in the following manner:

- (1) Loosen lock nut ① and turn the stopper bolt ② away from the stopper lug.
- (2) Loosen lock nut ③, and rotate the push rod ④ to locate the pedal 50 - 60 mm below the top face of the foot rest. Be sure to measure this clearance carefully.
- (3) Retighten lock nut ③ to secure the push rod ④ in the proper position.
- (4) Adjust the clearance between the tip of the return stopper bolt ⑤ and the stopper lug so that the clearance is zero. Retighten the lock nut ①.

REAR BRAKE LIGHT SWITCH

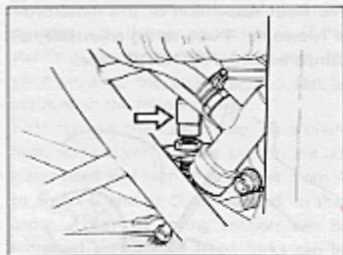

The rear brake light switch is located under the right frame cover. To adjust the brake light switch: raise or lower the switch so that the brake light will come on just before a pressure rise is felt when the brake pedal is depressed.

TYRES

Check the tyre inflation pressure and tyre tread condition at the periodic inspection. For maximum safety and good tyre life, the tyre pressures should be inspected more often.

TYRE PRESSURE

Insufficient air pressure in the tyres not only hastens tyre wear but also seriously affects the stability of the motorcycle. Under inflated tyres make smooth cornering difficult and overinflated tyres decrease the amount of tyre in contact with the ground which can lead to skids and loss of control. Be sure that the tyre pressure is within the specified limits at all times. Tyre pressure should only be adjusted when the tyres are cold.

COLD INFLATION TYRE PRESSURE	FRONT						REAR					
	SOLO RIDING			DUAL RIDING			SOLO RIDING			DUAL RIDING		
	kPa	P.S.I.	KG/CM ²	kPa	P.S.I.	KG/CM ²	kPa	P.S.I.	KG/CM ²	kPa	P.S.I.	KG/CM ²
NORMAL RIDING	175	24	1.75	200	28	2.00	200	28	2.00	250	36	2.50
CONTINUOUS HIGH SPEED RIDING	200	28	2.00	225	32	2.25	250	36	2.50	290	42	2.90

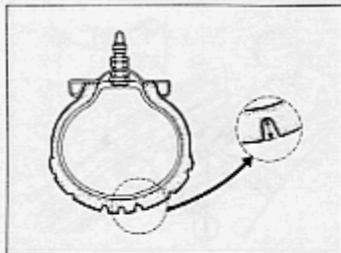

TYRE TREAD CONDITION

Operating the motorcycle with excessively worn tyres will decrease riding stability and can lead to loss of control. It is recommended that the front tyre be replaced when the remaining depth of tyre tread becomes 1.6 mm (0.06 in) or less. The rear tyre should be replaced when the tread becomes 2.0 mm (0.08 in) or less.

WARNING:

The standard tyre on your motorcycle is 3.50V19 4PR for front, 4.50V17 4PR for rear. The use of a tyre other than standard may cause trouble. It is highly recommended to use a SUZUKI Genuine Tyre.

WARNING:

Tyre inflation pressures and the general tyre condition are extremely important to the proper performance and safety of the vehicle. Check your tyres frequently for both wear and inflation pressures.

FRONT SUSPENSION

The front suspension of this motorcycle is telescopic, 4-way spring adjustable, oil damped with ANTI DIVE type.

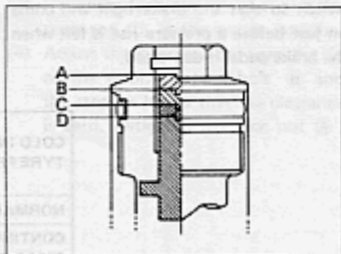
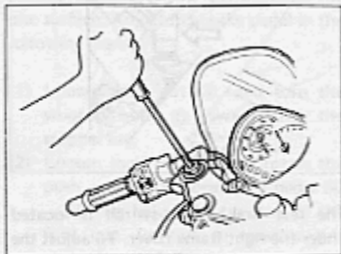

OWNERS CLUB
U.K.

SPRING ADJUSTMENT

The standard front fork spring setting position is at the spring tension C. If this standard setting provides too soft for your cruising, the spring tension can be adjusted in the following way.

First remove the rubber cap, fit a plain-head screwdriver into the slot on the adjuster head and turn it clockwise from A to B, to C and to D, if required, in that order. Thus the spring tension can be increased so that the front forks can be properly adjusted.

WARNING:

Making one front fork spring harder than the other will severely disturb the running stability. Always make sure the adjusters are right in position, not in between the spring position.

REAR SUSPENSION

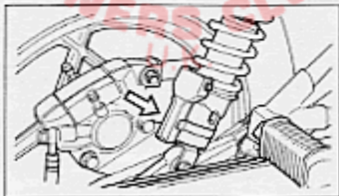
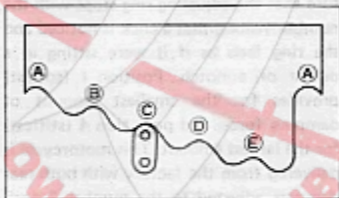
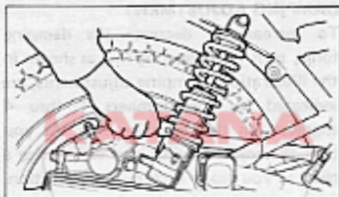

The rear shock absorber's spring preload and damping rate are adjustable. Spring preload can be altered to five different settings and the damping rate to four different settings.

These two variables can be adjusted to optimize the handling of the machine and the smoothness of the ride based on the speed, load, and road conditions.

SPRING ADJUSTMENT

The rear shock absorbers spring can be adjusted to meet road condition and motorcycle speed. To change the spring preload setting **C**, turn the bottom adjuster lever clockwise to the desired notch. Position **A** provides the softest spring tension and position **E** provides the stiffest spring tension.

CAUTION:

Set the adjuster lever so that it does not contact the muffler.

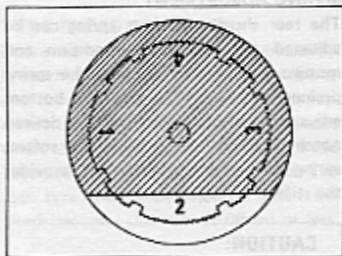
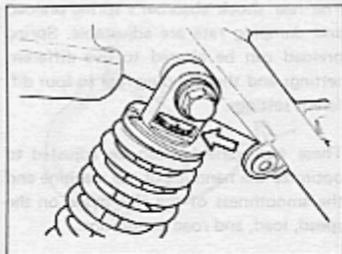

DAMPING ADJUSTMENT

To increase or decrease the damping force, turn this adjusting ring as shown in the illustration. Damping adjustments, are indicated by the numbers 1 thru 4 engraved on the adjusting ring. As you turn the adjusting ring, you will notice a click as you reach each number position. When changing the damping, always be sure that the adjusting ring stops with the number visible, that a click is noticed and the ring feels as if it were sitting in a detent or a notch. Position 1 (softest) provides for the smallest amount of damping force, and position 4 (stiffest) for the largest amount. This motorcycle is delivered from the factory with both rear dampers adjusted to the number 2 position.

CAUTION:

Do not operate rear damper units in any positions other than the click or detented positions. If positions 2½, 3½, etc. are used, the damping force will automatically have the same damping force as number 4 (stiffest) position.

The rear suspension can be adjusted in accordance with your type of riding, road condition, speed, passenger weight, carrying load and etc.

A list of the recommended combinations is provided and should be followed.

WARNING:

Be sure to adjust the springs and dampers of the two shock absorbers equally. Making one shock absorber harder than the other will severely disturb the running stability of the machine.

Spring Setting

A
B
C
D
E

Damper Setting

1 or 2
2 or 3
2 or 3
3 or 4
3 or 4

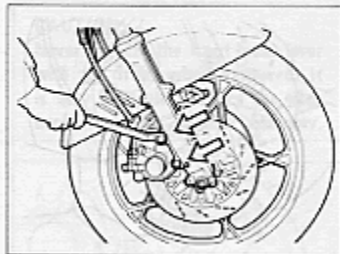
FRONT WHEEL REMOVAL

- (1) Place the bike on the center stand.
- (2) Remove either one of two calipers, left or right, from the fork by unfastening its two mounting bolts.

CAUTION

To secure the axle properly, the axle holders should be tightened down so that the gap on each side of the cup is equal.

KATANA

OWNERS CLUB
U.K.



- (3) Disconnect the speedometer cable from the front wheel. When the cable is released, prevent the inner drive cable from sliding out of the outer cable housing.

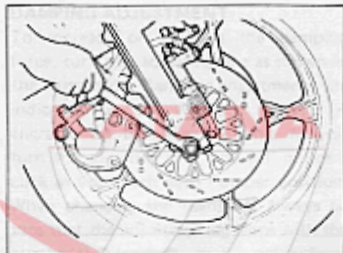

- (4) Loosen the axle nut.



- (5) Draw out the axle shaft.

CAUTION:

If once being removed self-lock nut can not be utilized twice as the self-lock nut effect is lost, consequently, in case of fastening the articles, utilize a new self-lock nut without fail.

U.K.

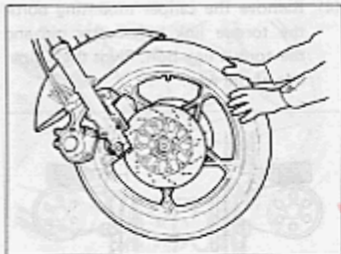

- (6) Lift the front end of the motorcycle up and place a jack or a block under the engine or chassis tubes.
- (7) Slide the front wheel forward. To reinstall the wheel assembly reverse the sequence as described.

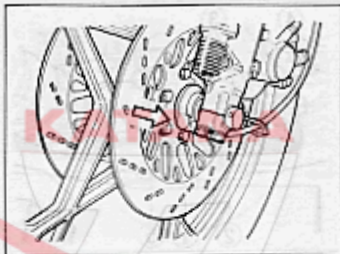
**CAUTION:**

Before tightening the axle in place, locate the speedometer drive gear box as indicated above illustration.

WARNING:

If the front wheel has to be removed, it is very important to have the loosened nuts and bolts torqued to the proper specifications. We suggest that you have this performed by a authorized Suzuki Dealer.

CAUTION:

Never squeeze the front brake lever with the front wheel removed. It is very difficult to force the pads back into the caliper assembly.

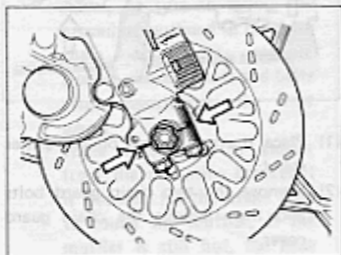
**CAUTION:**

To secure the axle properly, the axle holders should be tightened down so that the gap on each side of the cap is equal.

REAR WHEEL REMOVAL

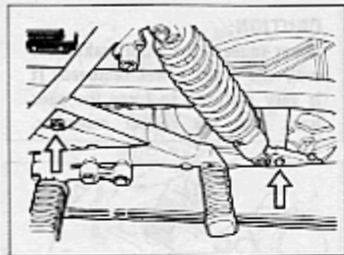

- (1) Place the motorcycle on the center stand.
- (2) Remove the two chain guard bolts and then remove the chain guard cover.

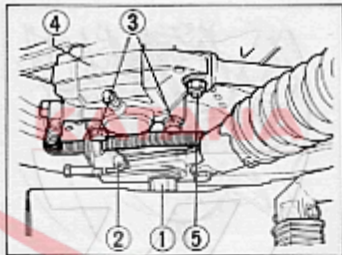

- | | |
|-------------------------|--------------------|
| ① Axle nut | ④ Caliper |
| ② Support bolt | ⑤ Torque link bolt |
| ③ Caliper mounting bolt | |
- (3) Loosen the axle nut.

CAUTION:

If once being removed self-lock nut can not be utilized twice as the self-lock nut effect is lost, consequently, in case of fastening the articles, utilize a new self-lock nut without fail.

- (4) Remove the caliper mounting bolts, the torque link bolt cotter pin and the torque link bolt. Pivot the caliper out of the way.

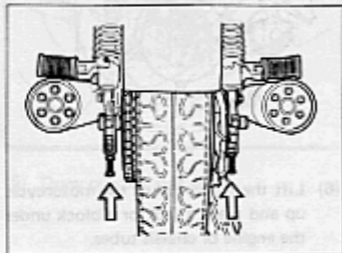

- (5) Pivot both chain adjusters downward, allowing the wheel to be pushed forward.
- (6) Remove the support bolts from each chain adjuster block and remove the adjuster block from swingarm.

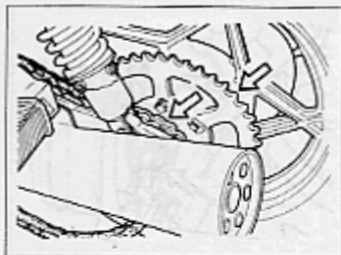

- (7) With the wheel moved forward, remove the chain from the sprocket by slowly rotating the wheel, at the same time pulling the chain to the side.

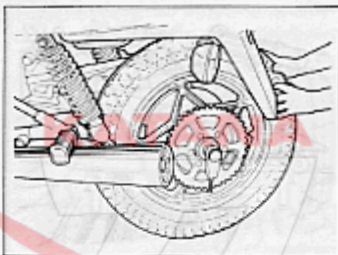

- (8) Pull the wheel assembly rearward and remove it from the swingarm. Slide the drive chain off of the hub when the wheel is far enough to the rear to provide the clearance required.
- (9) To replace the wheel reverse the complete sequence listed.

WARNING:

If you have found it necessary to remove the rear wheel, it is very important that the nuts and bolts be torqued to the proper specification. We strongly recommend

that you have these bolts checked and retorqued by your authorized Suzuki Dealer.

CAUTION:

- (1) When reinstalling the rear wheel, be sure to follow the procedure outlined in the drive chain adjustment section. Double check all nuts and bolts after reinstalling the rear wheel.
- (2) While removing the caliper from the mounting bracket it is possible for the brake hose to touch the muffler. If the muffler is still hot, the hose could be damaged. Protect the hose with a cloth or wait until the muffler cools.
- (3) When reinstalling the rear caliper, be careful not to twist the brake hose or route it improperly.

LIGHT BULB REPLACEMENT

The wattage rating of each bulb is shown on the chart below. When replacing a burned out bulb, always use the exact same wattage rating. Using other than the specified rating can result in overloading the electrical system or premature failure of a bulb.

Headlight	12V 60/55W
Tail/Brake light	12V 5/21W.....England 12V8/23W.....other market
License plate light	12V 5W.....England 12V 8W.....other market
Turn signal light	12V 21W.....England 12V 23W.....other market
Parking light	12V 4W

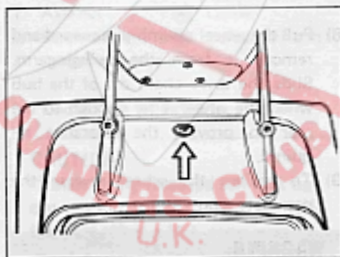
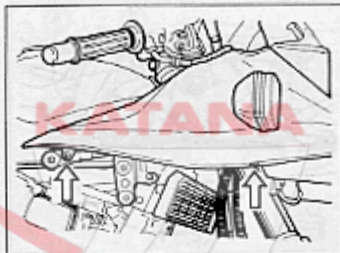

HEADLIGHT

- (1) Loosen five screws and take off the fairing.

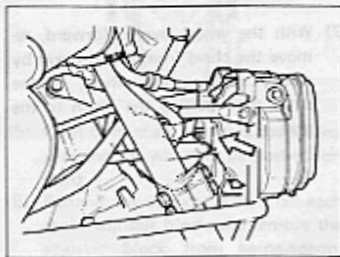
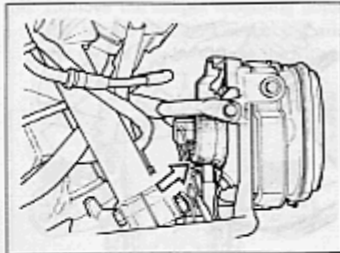

- (2) Roll up the rubber cap and disconnect the wiring socket.
- (3) Push the bulb stopper ring, twisting it counter-clockwise and pull out the bulb.

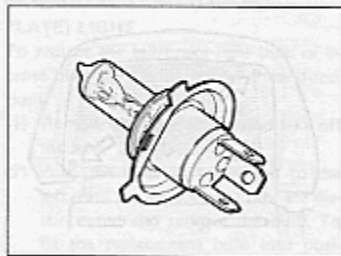

- (4) To fit the replacement bulb, set it to headlight and secure it with the bulb stopper ring.

CAUTION:

In this motorcycle, the halogen lamp is used for the headlight. When replacing the headlight bulb, be careful not to touch the lens of its bulb.

WARNING:

After remounting the headlight assembly, be sure to check the horizontal adjustment.

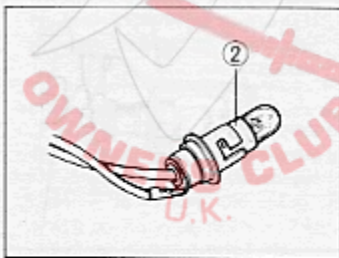
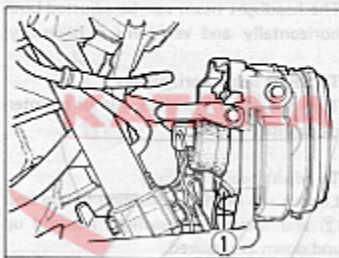

PARKING LAMP

- (1) Push the socket ①, twisting it to the left, and pull it off.
- (2) Remove the bulb ②, twisting it to the left, and pull it off.
- (3) To fit the replacement bulb push it in and twist it to the right while pushing.

HEADLIGHT ADJUSTMENT

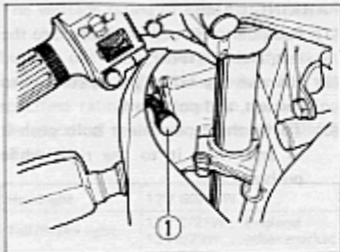

The headlight beam can be adjusted both horizontally and vertically if necessary.

To adjust beam horizontally:

Turn the knob (1) clockwise or counter-clockwise.

To adjust beam vertically:

Loosen the headlight housing fitting bolt (2) and move the headlight housing up and down as required.

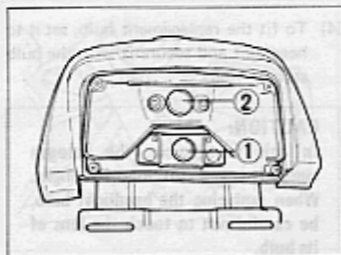
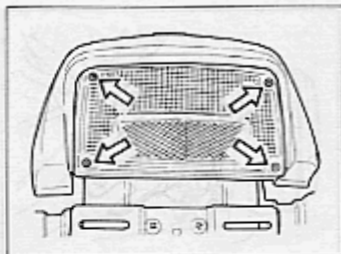
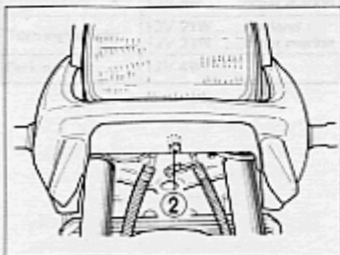

- ① Licence plate light
- ② Tail/Brake light

TAIL/BRAKE LIGHT (LICENSE PLATE) LIGHT

To replace the tail/brake light bulb or license plate light bulb, follow these directions:

- (1) Remove the four screws and take off the lens.
- (2) Push the bulb in, twisting it to the left until the engagement pins are disconnected and remove the bulb. To fit the replacement bulb into position, push the bulb in firmly and twist it to the right while pushing in.

CAUTION:

When replacing the lens, do not overtighten the four securing screws.

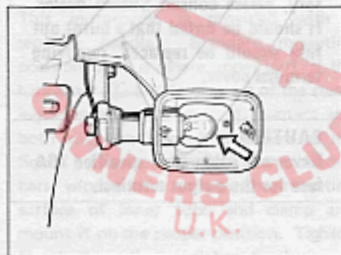
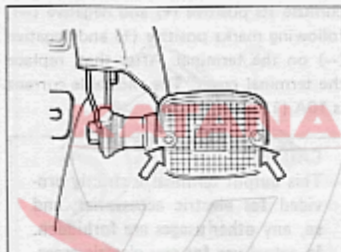

TURN SIGNAL LIGHT

- (1) Remove two screws and take off the lens.
- (2) Push the bulb, twisting it to the left, and pull it off.
- (3) To fit the replacement bulb, push it in and twist it to the right while pushing.

CAUTION:

After setting the lens, be careful not to overtighten the two securing screws lest the lens should break.

FUSE BOX/OUTPUT TERMINAL

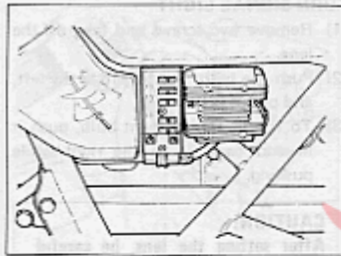

The fuse box/output terminal is located under the left hand frame cover. There are five fuses. If there is a sudden halting of the engine while running or any electrical system failure then the fuses must be checked. In case one or more of the fuses blow there are two spare fuses, a 15A and a 10A fuses, located in the fuse box cover.

For attaching electric accessories, this output terminal is provided.

When feeding current to an electric accessory from this output terminal, first remove terminal cover. Then, connect it to the terminal with extreme care not to

confuse its positive (+) and negative (-), following marks positive (+) and negative (-) on the terminal. After that, replace the terminal cover. The allowable current is 10A (12V).

CAUTION:

This output terminal is strictly provided for electric accessories, and so, any other usages are forbidden. In actual use for any electric accessory, please consult Suzuki dealer. It should be noted that a burnt out fuse should be replaced, removing terminal cover.

CAUTION:

Never use other than specified 10A fuse for the output terminal.

CAUTION:

Always be sure to replace the blown fuse with the correct amperage fuse. Never use a substitute, for example aluminum foil or wire, to replace a blown fuse. If the spare fuse installed blows out in a short period of time it means that your could have a major electrical problem. You should consult your Suzuki dealer immediately.

FUSE LIST

1. 15A MAIN fuse protects all electrical systems.
2. 10A HD. LAMP fuse protects headlight, taillight, license plate light, instrument light and high beam indicator light.
3. 10A SIGNAL fuse protects brake light, turn signal lights, turn signal indicator light and horn.
4. 10A IGNITION fuse protects the ignition system and electrical start system.
5. 10A OUTPUT TERMINAL fuse protects the electric accessories.

OPTION SWITCH

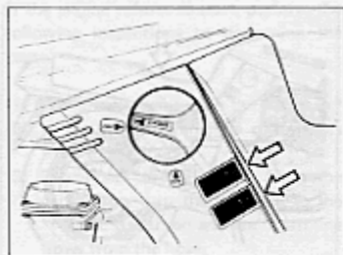

The option switch can be used as a switch when electric accessories are installed. Pushing the switch closes the electric circuit and when it is pushed again, the circuit is opened. When installing an electric accessory, power should be supplied from the output terminal.

CAUTION:

A large wattage electric accessory may cause the battery to run down faster or damage the electrical system. We suggest that you have this performed by an authorized Suzuki dealer.

HANDLEBAR SETTING

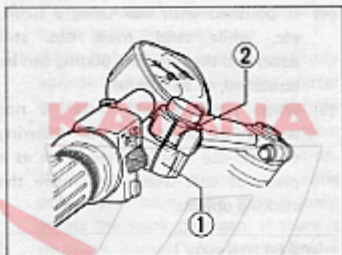

This motorcycle is provided with a separate handle. Standard mounting position of it is where upper part of the handlebar ① and lower part of the steering stem upper bracket ② contact and both slits are aligned as shown in the figure. In case of resetting the handlebars, wipe off the stain on the mounting surface of inner tube and clamp and mount it on the proper position. Tighten four bolts on the handlebars firmly. In this case, the slits of the handlebars become uniform as shown in the figure. After tightening the bolts, turn the handlebar fully clockwise and counter-clockwise to make sure that a hand

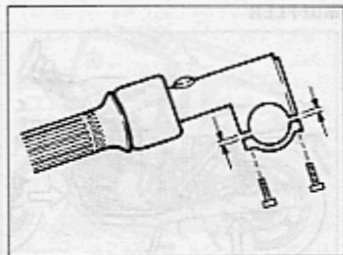

holding the handle does not hit the fuel tank. If hits, adjust the handlebar by loosening the bolts, so that both right and left sides of handlebars become the same angle.

CAUTION:

When resetting the handlebars, it is very important to set the handlebars in the proper positions and to tighten with the specified torque. We recommend that such work should be done by the authorized Suzuki Dealer.

CLEANING OF EXHAUST PIPE AND MUFFLER

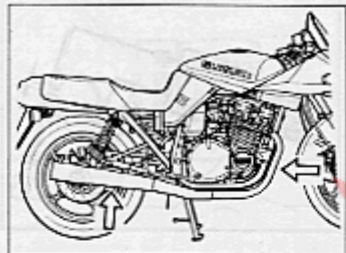

Method of care (handling)

- (1) Remove dirt and adhering objects with neutral detergent and water.
- (2) After washing with water wipe thoroughly.
- (3) Wipe with a cloth dipped in a small amount of oil.
(Or alternatively, polish with wax.)

NOTE: Do not use silicon or compound wax.

- (4) If polished with wax using a cloth, etc. while sand, mud, etc. still adhere to the pipe, the plating can be scratched, so be careful.
- (5) When washing with water is not enough to remove dirt or adhering objects, use a soft object such as a piece of soft wood to remove the sticking objects.

CAUTION:

Be careful not to touch the exhaust pipe when it is hot; a hot exhaust pipe can burn.

CLEANING THE SEAT

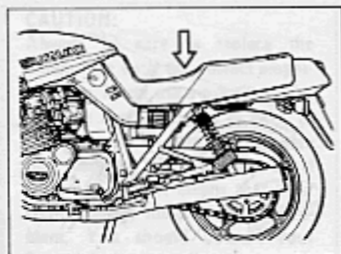

To clean a dirty or oil seat, wipe it with a rag damp with water or neutral detergent. If necessary, brush it lightly.

CAUTION:

Never use gasoline or alcohol as cleaning solvent. Not only will it damage the seat but it may catch fire. Be sure to use a neutral detergent.

If the engine refuses to start, perform the following inspections to determine the cause.

- (1) Is there enough fuel in the fuel tank?
- (2) Is the fuel reaching the carburetors from the fuelcock?
- (3) Disconnect the fuel line from the carburetor, turn the fuelcock to the "PRIME" position and see if gasoline flows from the hose.
- (4) Then turn the fuelcock to the "ON" position and crank the engine for a brief moment and see if fuel still flows.
- (5) If it has been determined that fuel is reaching the carburetor, the ignition system should be checked next.

WARNING:

Do not allow the fuel to spill, catch the fuel in a container.

- (1) Remove a spark plug and re-attach it to the spark plug lead.
- (2) While holding the spark plug firmly against the engine, push the starter button with the ignition switch in the "ON" position and the engine "kill" switch in the "RUN" position. If the ignition system is operating properly, a blue spark should jump across the spark plug gap. If there is no spark, consult your Suzuki Dealer for repairs.

WARNING:

Do not hold the spark plug close to the open spark plug hole in the cylinder head as gasoline vapor inside the cylinder could be ignited, creating a fire hazard.

ENGINE STALLING

- (1) Check the fuel supply in the fuel tank.
- (2) Check the ignition system for intermittent spark.
- (3) Check the engine idle speed.

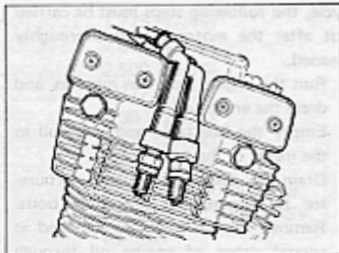
**CAUTION:**

It is best to consult your Suzuki dealer before attempting to troubleshoot any problem. If the machine is still within the warranty, then the Suzuki dealer should definitely be consulted before any repairs are attempted on the machine by yourself. Tampering with the machine while in warranty may affect warranty consideration.

For long term storage of your motorcycle, the following steps must be carried out after the motorcycle is thoroughly cleaned.

1. Run the engine for a few minutes, and drain the engine oil.
2. Empty the fuel tank, and spray oil to the inside of the tank.
3. Drain the gasoline from each carburetor by unscrewing the drain bolts.
4. Remove the spark plugs, and feed in several drops of engine oil through each plug hole. Turn over crankshaft slowly a number of times, and reinstall the spark plugs.
5. Spray oil to the exposed metal surfaces; be careful not to wet brake parts with oil. Avoid spraying on nonmetal and painted parts.
6. Remove battery, and store it in a dry and cool place (not in a freezing place).

NOTE: During storage, the battery must be recharged slowly once a month.

7. Deflate the tyres about 20 – 30%, and block up the engine to keep the tyres off the ground.

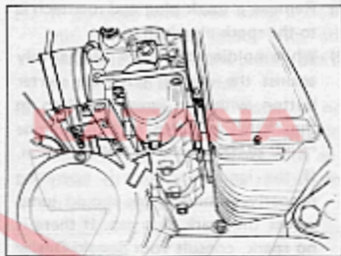

To take the motorcycle out of storage.

- 1) remount the battery,
- 2) pour in the engine oil,
- 3) lubricate the parts as instructed in Lubrication section,
- 4) inflate the tyres,
- 5) carry out the daily inspections before riding out.

SPECIFICATIONS

DIMENSIONS AND DRY MASS

Overall length	2 260 mm (89.0 in)
Overall width	715 mm (28.1 in)
Overall height	1 205 mm (47.4 in)
Wheelbase	1 520 mm (59.8 in)
Ground clearance	175 mm (6.9 in)
Dry mass	232 kg (511 lbs)

ENGINE

Type	Four-stroke, air cooled, DOHC
Number of cylinders	4
Bore	72.0 mm (2.835 in)
Stroke	66.0 mm (2.598 in)
Piston displacement	1 075 cm ³ (65.6 cu. in)
Compression ratio	9.5 : 1
Carburetor	MIKUNI BS34SS, four
Air cleaner	Dual element (Paper and polyurethane foam)
Starter system	Electric
Lubrication system	Wet sump

TRANSMISSION

Clutch	Wet multi-plate type
Transmission	5-speed constant mesh
Gearshift pattern	1-down, 4-up

Primary reduction	1.775 (87/49)
Final reduction	2.800 (42/15)
Gear ratios, Low	2.500 (35/14)
2nd	1.777 (32/18)
3rd	1.380 (29/21)
4th	1.125 (27/24)
Top	0.961 (25/26)
Drive chain	DAIDO D.I.D.630YL or TAKASAGO RK630GSV, 96 links

CHASSIS

Front suspension	Telescopic, spring 4-way adjustable, oil dampened, with ANTI-DIVE
Rear suspension	Swinging arm, oil dampened, damper 4-way/spring 5-way adjustable
Steering angle	30° (right & left)
Caster	61° 50'
Trail	118 mm (4.6 in)
Turning radius	3.5 m (11.5 ft)
Front brake	Disc brake, twin
Rear brake	Disc brake
Front tire size	3.50V19 4PR
Rear tire size	4.50V17 4PR

ELECTRICAL

Ignition type	Transistorized
Ignition timing	12° B.T.D.C. below 1 500 r/min and 32° B.T.D.C. above 2 350 r/min
Spark plug	NGK D8EA or NIPPON DENSO X24ESR-U.....For General market and Australia NGK DR8ES or NIPPON DENSO X24ESR-U.....For England and South Africa
Battery	12V 50.4 kC (14 Ah)/10 HR
Generator	Three-phase A.C. Generator
Fuse	10/10/10/15/10A
Headlight	12V 60/55W
Tail/Brake light	12V 5/21W.....For England 12V 8/23W.....For other market
Turn signal light	12V 21W.....For England 12V 23W.....For other market
License plate light	12V 5W.....For England 12V 8W.....For other market
Speedometer light	12V 3.4W
Tachometer light	12V 3.4W
Neutral indicator light	12V 3.4W
High beam indicator light	12V 3.4W
Turn signal indicator light	12V 3.4W
Oil P. indicator light	12V 3.4W
Parking or city light	12V 4.0W

CAPACITIES

Fuel tank including reserve	22 L (5.8/4.8 US/Imp gal)
reserve	5.0 L (5.3/4.4 US/Imp qt)
Engine oil	3.2 L (3.4/2.8 US/Imp qt.)
Front fork oil	227 ml (7.67/7.99 US/Imp oz)

WIRING DIAGRAM

(FOR ENGLAND)

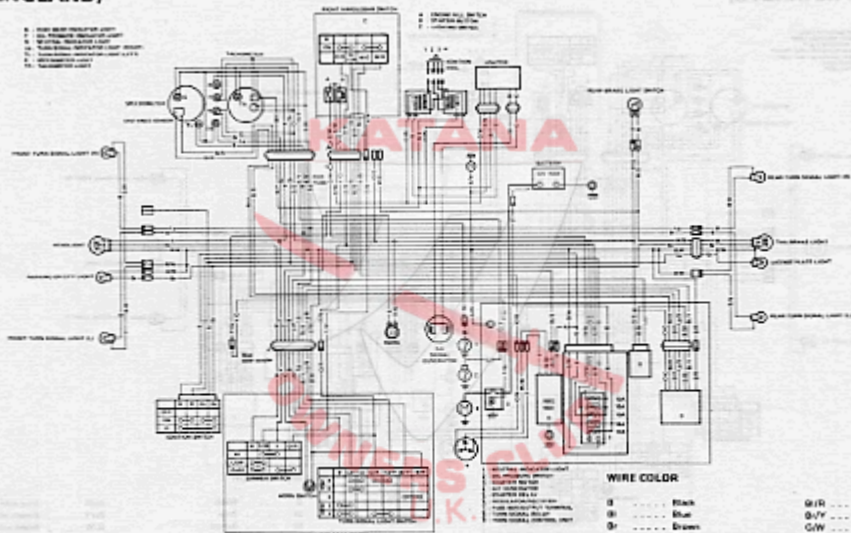

WIRE COLOR

B	Black	B/R	Blue with Red tracer
Bl	Blue	B/W	Blue with White tracer
Br	Brown	G/Y	Green with Yellow tracer
G	Green	LgT	Light green with Black tracer
Gr	Grey	OV	Orange with Green tracer
LM	Light blue	OVH	Orange with Red tracer
Lg	Light green	OW	Orange with White tracer
O	Orange	WB	White with Blue tracer
R	Red	W/S	White with Green tracer
W	White	W/R	White with Red tracer
Y	Yellow	Y/B	Yellow with Black tracer
B/B	Black with Blue tracer	Y/G	Yellow with Green tracer
B/R	Black with Red tracer	Y/W	Yellow with White tracer
B/W	Black with White tracer		
B/Y	Black with Yellow tracer		

(FOR OTHER MARKETS)

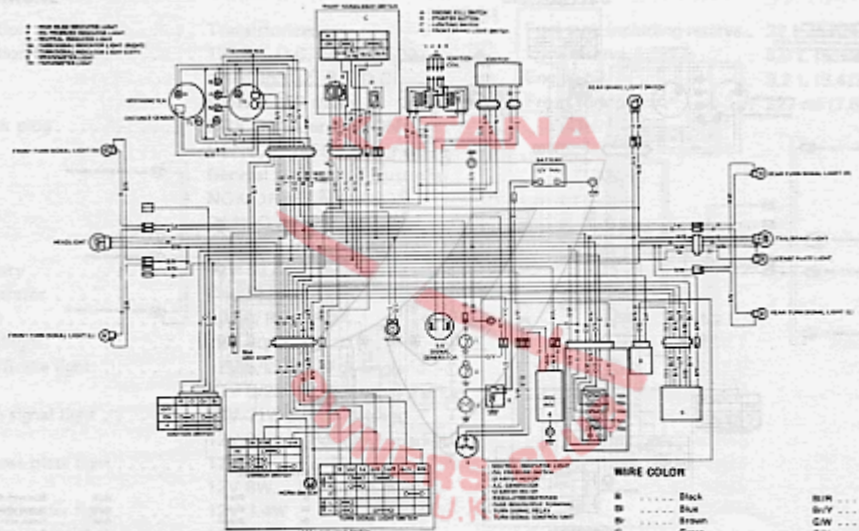

WIRE COLOR

B	Black	B/R	Blue with Red tracer
Bl	Blue	B/Y	Blue with Yellow tracer
Br	Brown	G/W	Green with White tracer
Gr	Green	G/Y	Green with Yellow tracer
Gr	Grey	L/B	Light green with Black tracer
Lg	Light blue	O/C	Orange with Green tracer
Lg	Light green	O/R	Orange with Red tracer
O	Orange	O/W	Orange with White tracer
R	Red	W/B	White with Blue tracer
Wh	White	W/G	White with Green tracer
Y	Yellow	W/R	White with Red tracer
B/B	Black with Blue tracer	Y/B	Yellow with Black tracer
B/R	Black with Red tracer	Y/G	Yellow with Green tracer
B/W	Black with White tracer	Y/W	Yellow with White tracer
B/Y	Black with Yellow tracer		

KATANA

Prepared by

SUZUKI MOTOR CO., LTD.

Administration Department
Overseas Service Division

May, 1981

Part No. 99011-49320-01A

Printed in Japan

U.K.

KATANA



SUZUKI MOTOR CO., LTD.

OWNERS CLUB

U.K.

h

Part No. 99011-49320-01A
August, 1981 ①
Printed in Japan